

Operating Manual

SemiChill Recirculating Coolers

Eco-Series

SC2500a
air cooled

SC2500w
water cooled

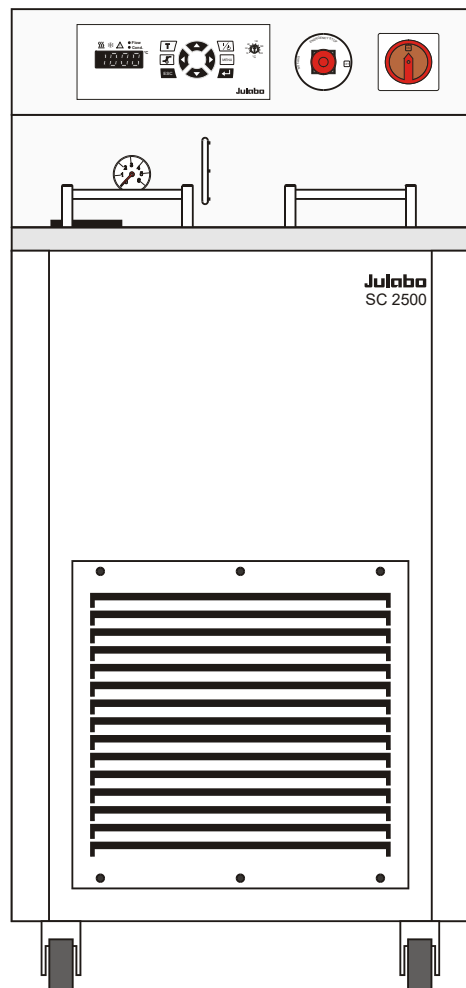

Julabo
THE TEMPERATURE CONTROL COMPANY

JULABO USA, Inc.
884 Marcon Boulevard
Allentown, PA 18109
Phone: +1(610) 231-0250
Fax: +1(610) 231-0260
info@julabo.us
www.julabo.us

Congratulations!

You have made an excellent choice.

JULABO thanks you for the trust you have placed in us.

This operating manual has been designed to help you gain an understanding of the operation and possible applications of our circulators. For optimal utilization of all functions, we recommend that you thoroughly study this manual prior to beginning operation.

Unpacking and inspecting

Unpack the circulator and accessories and inspect them for possible transport damage. Damage should be reported to the responsible carrier, railway, or postal authority, and a damage report should be requested. These instructions must be followed fully for us to guarantee our full support of your claim for protecting against loss from concealed damage. The form required for filing such a claim will be provided by the carrier.

Important: keep original operating manual for future use

TABLE OF CONTENTS

1. Intended use	5
1.1. Description	5
2. Operator responsibility – Safety instructions	5
2.1. Disposal	7
2.2. Technical specifications	8
2.3. Cooling water connection	11
3. Operating controls and functional elements	12
4. Safety notes for the user	14
4.1. Explanation of safety notes	14
4.2. Explanation of other notes	14
4.3. Safety instructions	15
5. Preparations	17
5.1. Installation	17
5.2. Connecting the external system	18
5.2.1. Tubing	19
5.2.2. Bath fluids	19
5.3. Filling	20
5.4. Draining	21
6. Operating procedures	22
6.1. Power connection	22
6.2. Switching on / Start - Stop	22
6.3. AUTOSTART ON / OFF	23
7. Setting the temperatures	24
8. Safety installations, warning functions	24
8.1. Excess temperature protection	24
8.2. Early warning system, low level protection	25
8.3. High and low temperature warning functions	26
8.4. Limitation of the operating temperature range	27
8.5. Change-over of the warning function to shutdown function	28
9. Menu functions	29
9.1. Setting the pump pressure	30
9.2. ATC Absolute Temperature Calibration, 3-point calibration	30

9.3. Remote control: activate – deactivate	33
9.4. Interface - Baud rate, Handshake, Parity	33
9.5. Control parameters – Xp, Tv, Tn	34
9.6. Reset.....	36
10. Troubleshooting guide / Error messages	36
11. Electrical connections.....	38
12. Remote control	39
12.1. Setup for remote control	39
12.2. Communication with a PC or a superordinated data system.....	39
12.3. List of commands.....	40
12.4. Status messages	42
12.5. Error messages.....	42
13. JULABO Service – Online remote diagnosis	43
14. Cleaning / repairing the unit	44
15. WARRANTY PROVISIONS	45

1. Intended use

JULABO recirculating coolers have been designed to control the temperature of specific fluids in a bath tank. The units feature pump connections for temperature control of external systems (loop circuit).



JULABO recirculating coolers are not suitable for direct temperature control of foods, semi-luxury foods and tobacco, or pharmaceutical and medical products. Direct temperature control means unprotected contact of the object with the bath medium (bath fluid).

1.1. Description

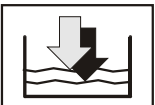
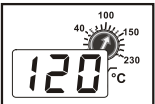
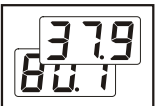

- The recirculating coolers are operated via the splash-proof keypad. The implemented microprocessor technology allows to set and to store different values that can be indicated on the MULTI-DISPLAY (LED). Three menu keys facilitate adjusting setpoints, warning and safety functions and menu functions.
- The PID temperature control adapts the heat supplied to the thermal requirements of the bath.
- Absolute Temperature Calibration (ATC3) provides a high temperature stability in the bath. With the 3-point calibration an offset is adjusted at three temperatures to ensure an accurate temperature pattern at the selected spot in the bath over the full temperature range.
- Electrical connections:
The serial interface RS232 allows modern process technology without additional interface.
- The excess temperature protection conforming to IEC 61010-2-010 is a safety installation independent from the control circuit. This protection can be indicated and set on the MULTI-DISPLAY (LED).
- The early warning system for low level signals that bath fluid needs to be refilled before the low level protection conforming to IEC 61010-2-010 causes a complete shut-down of the main functional elements.
- The pump capacity (electronically adjustable via the motor speed) enables to adapt to varying conditions for internal and external temperature applications.

2. Operator responsibility – Safety instructions

The products of JULABO ensure safe operation when installed, operated, and maintained according to common safety regulations. This section explains the potential dangers that may arise when operating the circulator and also specifies the most important safety precautions to preclude these dangers as far as possible.

The operator is responsible for the qualification of the personnel operating the units.

- The personnel operating the units should be regularly instructed about the dangers involved with their job activities as well as measures to avert these dangers.
- Make sure all persons tasked with operating, installing, and maintaining the unit have read and understand the safety information and operating instructions.

Operator responsibility – Safety instructions

- When using hazardous materials or materials that could become hazardous, the circulator may be operated only by persons who are absolutely familiar with these materials and the circulator. These persons must be fully aware of possible risks.

If you have any questions concerning the operation of your unit or the information in this manual, please contact us!

Contact

JULABO USA, Inc.
884 Marcon Boulevard
Allentown, PA 18109

Phone: +1(610) 231-0250
Fax: +1(610) 231-0260
info@julabo.us
www.julabo.us

Safety instructions for the operator:

- Avoid strikes to the housing, vibrations, damage to the operating-element panel (keypad, display), and contamination.
- Make sure the product is checked for proper condition regularly (depending on the conditions of use). Regularly check (at least every 2 years) the proper condition of the mandatory, warning, prohibition and safety labels.
- Make sure that the mains power supply has low impedance to avoid any negative effects on the instruments being operated on the same mains.
- This unit is designed for operation in a controlled electromagnetic environment. This means that transmitting devices (e.g., cellular phones) should not be used in the immediate vicinity.
- Magnetic radiation may affect other devices with components sensitive to magnetic fields (e.g., monitors). We recommend maintaining a minimum distance of 1 m.
- Permissible ambient temperature: max. 40 °C, min. 5 °C.
- Permissible relative humidity: 50% (40 °C).
- Do not store the unit in an aggressive atmosphere. Protect the unit from contamination.
- Do not expose the unit to sunlight.

Appropriate operation

Only qualified personnel is authorized to configure, install, maintain, or repair the circulator. Persons who operate the circulator must be trained in the particular tasks by qualified personnel. The summarized user guidance (short manual) and the specification table with information on individual parameters are sufficient for this.

Use

The bath can be filled with flammable materials. Fire hazard!



There might be chemical dangers depending on the bath medium used.

Observe all warnings for the used materials (bath fluids) and the respective instructions (safety data sheets).

Insufficient ventilation may result in the formation of explosive mixtures. Only use the unit in well ventilated areas.

Only use recommended materials (bath fluids). Only use non-acid and non corroding materials.

When using hazardous materials or materials that could become hazardous, the operator must affix the enclosed safety labels (1 + 2) to the front of the unit so they are highly visible:

1		Danger area. Attention! Observe instructions. (operating manual, safety data sheet)
2		Carefully read the user information prior to beginning operation. Scope: EU
or 2		Carefully read the user information prior to beginning operation. Scope: USA, NAFTA

Particular care and attention is necessary because of the wide operating range.
There are thermal dangers: Burn, scald, hot steam, hot parts and surfaces that can be touched.

	Hot surface warning. (The label is put on by JULABO)
---	---

Observe the instructions in the manuals for instruments of a different make that you connect to the circulator, particularly the corresponding safety instructions. Also observe the pin assignment of plugs and technical specifications of the products.

2.1. Disposal

The recirculating cooler contains a back-up battery that supplies voltage to the memory chips when the unit is switched off. Do not dispose of the battery with household waste!

Depending on battery regulations in your country, you may be obligated to return used or defective batteries to collection sites.

The product may be used with oil as bath fluid. These oils fully or partially consist of mineral oil or synthetic oil. For disposal, follow the instructions in the material safety data sheets.

This unit contains the refrigerant R452A, which at this time is not considered harmful to the ozone layer. However, over the long operating period of the unit, disposal rules may change. Therefore, only qualified personnel should handle the disposal.

2.2. Technical specifications

Performance specifications measured in accordance with DIN12876. Cooling capacities up to 20°C measured with ethanol; over 20°C with thermal oil unless specified otherwise. Performance specifications apply at an ambient temperature of 20°C. Performance values may differ with other bath fluids.

Eco- Series			SC2500a	SC2500w
Working temperature ranges:				
Standard unit		°C	+5 ... +35	+5 ... +35
Option	Low Temp		-20 ... +35	-20 ... +35
Option	Low /HighTemp I	°C	-20 ... +80	-20 ... +80
Temperature stability		°C	0.1	0.1
Absolute Temperature Calibration			±3	±3
Heater wattage (at 230 V) Option H1		kW	1.0	1.0
Cooling capacity		°C	<u>+20</u> 0 -10	<u>+20</u> 0 -10
		kW	2.5 1.5 0.9	2.5 1.5 0.9
Refrigerant			R452A	R452A
Pump capacity P3 see table 1 page 9				
Flow rate	P3	l/min at 0 bar	33	33
Pressure max.	P3	bar at 0 liters	3.5	3.5
Overall dimensions (WxDxH)		cm	49x62/105	49x62/105
Filling volume		liters	21 ... 33	21 ... 33
Weight		kg	123	123
Mains power connection	195-253V/50Hz	V/Hz	230 / 50	230 / 50
Current consumption	without heater	A	11 (230 V)	11 (230 V)
Current consumption	1 kW heater	A	15 (230 V)	15 (230 V)
Mains power connection	195-253 V/60 Hz	V/Hz	208-230 / 60	208-230 / 60
Current consumption	without heater	A	11 (230 V)	11 (230 V)
Current consumption	1 kW heater	A	15 (230 V)	15 (230 V)

* Pump P3- reduces cooling capacity by 0.3 kW

Eco- Series		
Temperature selection	digital	
via keypad	indication on LED-Multi-Display	
remote control via personal computer	indication on monitor	
Temperature indication	°C	LED-Multi-Display
Resolution	°C	0.1

Electrical connection:
Computer interface RS232

Table 1

Pump capacity Bath fluid: Water, Silicone -oil	XX . XX <i>PUMP</i> 1		XX . XX <i>PUMP</i> 2				
Circulating pump:		P3			P3		
Flow rate max. Lpm at 0 bar		30			33		
Pressure max. bar at 0 liters		1.8			3.5		
Bath fluid: Galden® eg. Fluorinert® 3283							
Pressure max. bar at 0 liters		3.5					



Notice:

If Galden® or Fluorinert® is used the charge of the motor increases. Wrong adjustment causes overheating and eventually destruction of the motor.

- With the circulation pump P3 a maximum pump pressure stage >PUMP 1< may be adjusted.

The pump type can be recognized in the order no. on the name plate.

95 xx xxx _ xx **PX** xx

Safety installations according to IEC 61010-2-010:

Excess temperature protection	adjustable from 0 °C ... 320 °C
Low liquid level protection	float switch
Classification according to DIN 12876-1	class III

Supplementary safety installations

Early warning system for low level	float switch
High temperature warning function	optical + audible (in intervals)
Low temperature warning function	optical + audible (in intervals)
Supervision of working sensor	plausibility control
Reciprocal sensor monitoring between working and safety sensors	difference >35 K
Alarm message	optical + audible (permanent)
Warning message	optical + audible (in intervals)

Environmental conditions according to IEC 61 010-1:

Use indoors only.

Altitude up to 2000 m - normal zero.

Ambient temperature: see Technical specifications

Humidity:

Max. relative humidity 80% for temperatures up to +31 °C,

linear decrease down to 50% relative humidity at a temperature of +40 °C

Max. mains voltage fluctuations of ±10% are permissible.

Protection class according to IEC 60 529	IP21
The unit corresponds to Class	I
Overvoltage category	II
Pollution degree	2



Caution:

The unit is not for use in explosive environment.

EMC requirements

The device is an ISM device of group 1 per CISPR 11 (uses HF for internal purposes) and is classified in class A (industrial and commercial sector).

Notice:

- Devices of class A are intended for the use in an industrial electromagnetic environment.
- When operating in other electromagnetic environments, their electromagnetic compatibility may be impacted.

2.3. Cooling water connection

Cooling water pressure (IN/OUT)	max.	6 bar
Pressure difference (IN - OUT)		3.5 to 6 bar
Cooling water temperature		< 20 °C



Notice: Cooling water circuit

Risk of oil leaking from the refrigeration system (compressor) of the recirculating cooler into the cooling water in case of a fault in the cooling water circuit!

Observe the laws and regulations of the water distribution company valid in the location where the unit is operated.



Notice:

Danger of corrosion of heat exchanger due to unsuitable quality of cooling water.

- Due to its high content of lime, hard water is not suitable for cooling and causes scale in the heat exchanger.
- Ferrous water or water containing ferrous particles will cause formation of rust even in heat exchangers made of stainless steel.
- Chlorinated water will cause pitting corrosion in heat exchangers made of stainless steel.
- Due to their corrosive characteristics, distilled water and deionized water are unsuitable and will cause corrosion of the bath.
- Due to its corrosive characteristics, sea water is not suitable.
- Due to its microbiological (bacterial) components, which settle in the heat exchanger, untreated and unpurified river water and water from cooling towers is unsuitable.
- Avoid particulate matter in cooling water.
- Avoid putrid water.

Recommended quality of cooling water:

pH	7.5 to 9.0
Sulfate [SO ₄ ²⁻]	< 100 ppm
Hydrocarbonate [HCO ₃ ⁻]/sulfate [SO ₄ ²⁻]	> 1 ppm
Hardness [Ca ²⁺ , Mg ²⁺]/[HCO ₃ ⁻]	> 0.5 °dH
Alkalinity	60 ppm < [HCO ₃ ⁻] < 300 ppm
Conductivity	< 500 µS/cm
Chloride (Cl ⁻)	< 50 ppm
Phosphate (PO ₄ ³⁻)	< 2 ppm
Ammonia (NH ₃)	< 0.5 ppm
Free chlorine	< 0.5 ppm
Trivalent iron ions (Fe ³⁺)	< 0.5 ppm
Manganese ions (Mn ²⁺)	< 0.05 ppm
Carbon dioxide (CO ₂)	< 10 ppm
Hydrogen sulfide (H ₂ S)	< 50 ppm
Content of oxygen	< 0.1 ppm
Algae growth	impermissible
Suspended solids	impermissible

3. Operating controls and functional elements

Front view

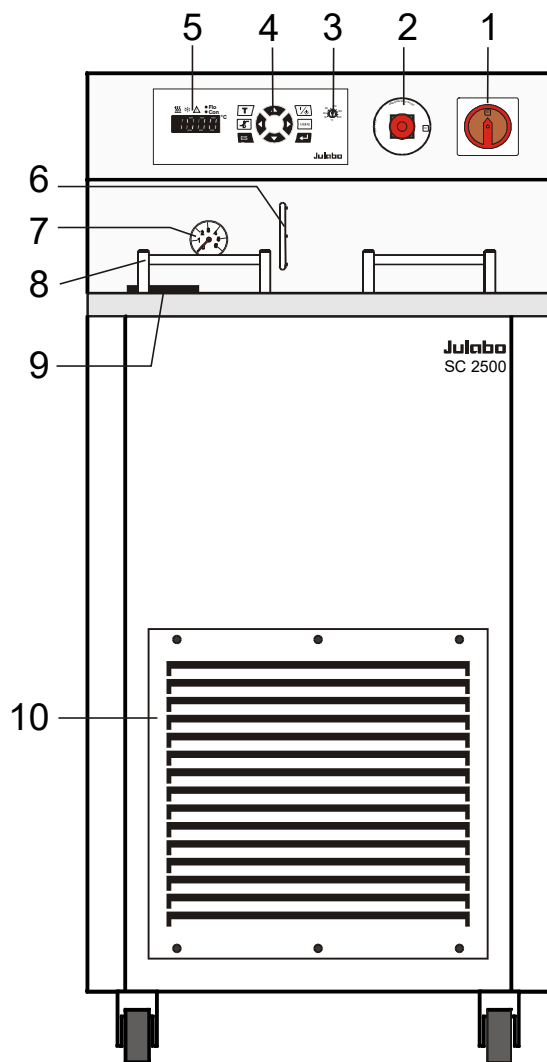

Rear view

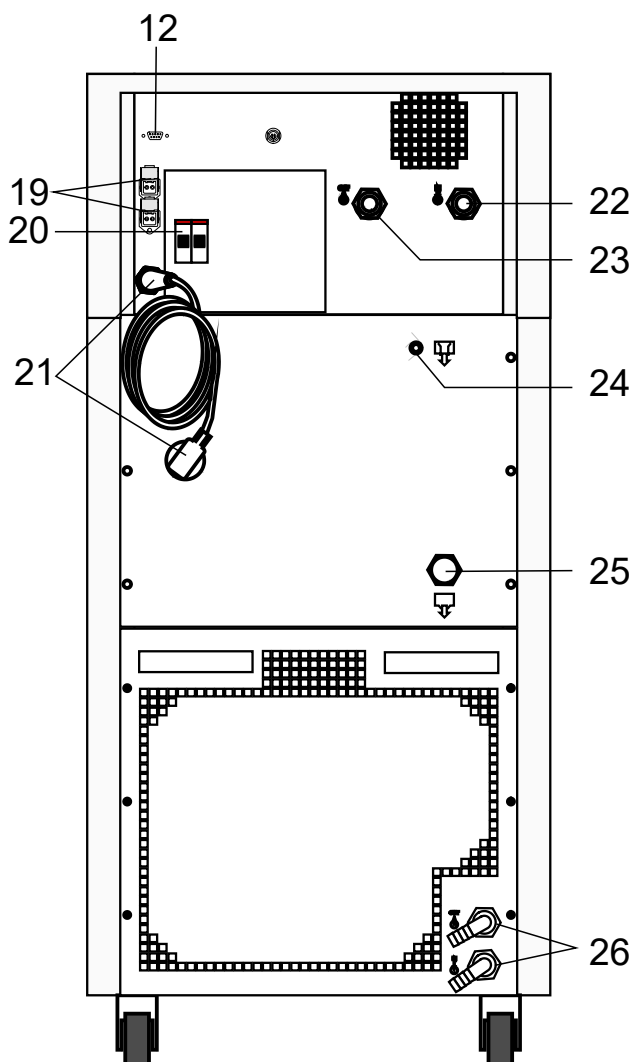

1 Mains power switch

2 Emergency stop switch

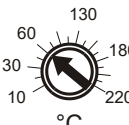
3  Adjustable excess temperature protection according to IEC 61010-2-010

4 Keypad



Start / stop key



Key for selecting the working temperature - Setpoint 1, 2, 3



Key for selecting the warning and safety values



MENU button - for selecting the menu functions















Cursor keys (left or right)



Edit keys (increase or decrease)

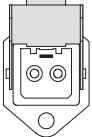

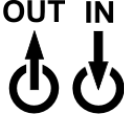
Enter key
1) Store value / parameter
2) Next lower menu level

		Escape key	1. Cancel entries 2. Return to a higher menu level
5		MULTI-DISPLAY (LED) temperature indication, menu indication	
5.1		Control indicator – Heating	
5.2		Control indicator – Cooling	
5.3		Control indicator – Alarm	
6		Filling level indication	
7		Manometer (feed pressure)	
8		Handle	
9		Filling opening	
10		Venting grid, removable (only air cooled recirculating cooler)	
12		Interface RS232: remote control via personal computer	
19		2 Connectors for solenoid valve. 230 V / max. 0.1 A No control voltage in the -OFF- condition	
20		2 Safety cutouts: Mains fuses 16 A	
		Motor protection circuit breaker for compressor motor	
21		Mains power cable with plug	
22		Pump connectors: 3/4" NPT male	
23		OUT / Feed	IN / Return
24		Overflow connector, M10x1 female Order-No. 8 970 460 Barbed fitting for tubing 8 mm inner dia.	

 Closable when using e.g. 3M Fluorinert[®] as temperature liquid.

25



Discharge nozzle with cap nut, Connection: ½ " male

Recommendation:

Before filling please install a drain cock at the discharge nozzle.
(not included in delivery)

Order-No. 8 920 100 Drain cock, stainless steel

26

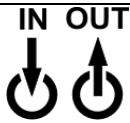

Only for water cooled models: Cooling water OUTLET and INLET

4. Safety notes for the user

4.1. Explanation of safety notes



In addition to the safety warnings listed above, warnings are posted throughout the manual. These warnings are designated by an exclamation mark inside an equilateral triangle. "Warning of a dangerous situation (Attention! Please follow the documentation)."

The danger is classified using a signal word.
Read and follow these important instructions.



Warning:

Describes a possibly highly dangerous situation. If these instructions are not followed, serious injury and danger to life could result.



Caution:

Describes a possibly dangerous situation. If this is not avoided, slight or minor injuries could result. A warning of possible property damage may also be contained in the text.



Notice:

Describes a possibly harmful situation. If this is not avoided, the product or anything in its surroundings can be damaged.

4.2. Explanation of other notes



Note!

Draws attention to something special.



Important!

Indicates usage tips and other useful information.

4.3. Safety instructions

Follow the safety instructions to avoid personal injury and property damage. Also, the valid safety instructions for workplaces must be followed.



- Only connect the unit to a power socket with an earthing contact (PE – protective earth)!
- The power supply plug serves as a safe disconnecting device from the line and must always be easily accessible.
- Place the unit on an even surface on a base made of nonflammable material.
- Do not stay in the area below the unit.
- Make sure you read and understand all instructions and safety precautions listed in this manual before installing or operating your unit.
- Set the excess temperature safety installation at least below the flash point of the bath fluid.
- Never operate the unit without bath fluid in the bath.
- Pay attention to the thermal expansion of bath oil during heating to avoid overflowing of the fluid.
- Prevent water from entering the hot bath oil.
- Do not drain the bath fluid while it is hot!
Check the temperature of the bath fluid prior to draining (e.g., by switching the unit on for a short moment).
- Use suitable connecting tubing.
- Avoid sharp bends in the tubing, and maintain a sufficient distance from surrounding walls.
- Make sure that the tubing is securely attached.
- Regularly check the tubing for material defects (e.g., for cracks).
- Never operate damaged or leaking units.
- Always turn off the unit and disconnect the mains cable from the power source before performing any service or maintenance procedures, or before moving the unit.
- Always turn off the unit and disconnect the mains cable from the power source before cleaning the unit.
- Always empty the bath before moving the unit.
- Transport the unit with care.
- Sudden jolts or drops may cause damage in the interior of the unit.
- Observe all warning labels.
- Never remove warning labels.
- Never operate units with damaged mains power cables.
- Repairs are to be carried out only by qualified service personnel.



- Some parts of the bath tank and the pump connections may become extremely hot during continuous operation. Therefore, exercise particular caution when touching these parts.



Caution:

The unit may be used, for example, to control the temperature of fluids in a reactor. We do not know what substances are contained in these vessels. Many substances are:

- inflammable, easily ignited, or explosive
- hazardous to health
- environmentally hazardous

i.e.: **dangerous**

The user alone is responsible for the handling of these substances!

The following questions should help to recognize possible dangers and to reduce the risks to a minimum.

- Are all tubes and electrical cables connected and layed?
Note:
sharp edges, hot surfaces in operation, moving machine parts, etc.
- Do dangerous vapors or gases develop during heating?
Must the work be done in a fume hood?
- What to do when a dangerous substance was spilled on or in the unit?
Before starting to work, obtain information concerning the substance and determine the method of decontamination.



Notice:

Check the safety installations at least twice a year!

- Excess temperature protection according to IEC 61010-2-010
With a screwdriver, turn back the adjustable excess temperature protection until the shutdown point (actual temperature).
- Low level protection according to IEC 61010-2-010
To check the function of the float, it can be manually lowered with a screwdriver, for example.



WARNING

This product contains chemicals known to the state of California to cause cancer, birth defects or other reproductive harm.

5. Preparations

5.1. Installation

- Place the unit in an upright position.
For better stability, apply the holding brakes on the front casters.
- The place of installation should be large enough and provide sufficient air ventilation to ensure the room does not warm up excessively because of the heat the instrument rejects to the environment. (Max. permissible ambient temperature: 35 °C).
For a fault (leakage) in the refrigeration system, the standard EN 378 prescribes a certain room space to be available for each kg of refrigerant.
The refrigerant quantity is specified on the type plate.
> For 0.432 kg of refrigerant R452A, 1 m³ of space is required.
- Keep at least 20 cm of open space on the front and rear venting grids.
- Do not set up the unit in the immediate vicinity of heat sources and do not expose to sun light
- Before operating the unit after transport, **wait about one hour after installation**. This will allow any oil that has accumulated laterally during transport to flow back down, thus ensuring that the compressor can develop its maximum capacity.

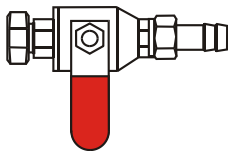

Recommendation:

Before filling please install a drain cock at the discharge nozzle. (25)
Connection: ½ " male (not included in delivery)

Order-No. 8 920 100 Drain cock, stainless steel

Cooling water connection (26)

Only for water cooled models:

Ensure circulation of cooling water by connecting the tubing to cooling water inlet and outlet on the rear of the recirculating cooler.

Cooling water connectors G3/4" external thread

Cooling water temperature <20 °C

Cooling water see page 11



5.2. Connecting the external system

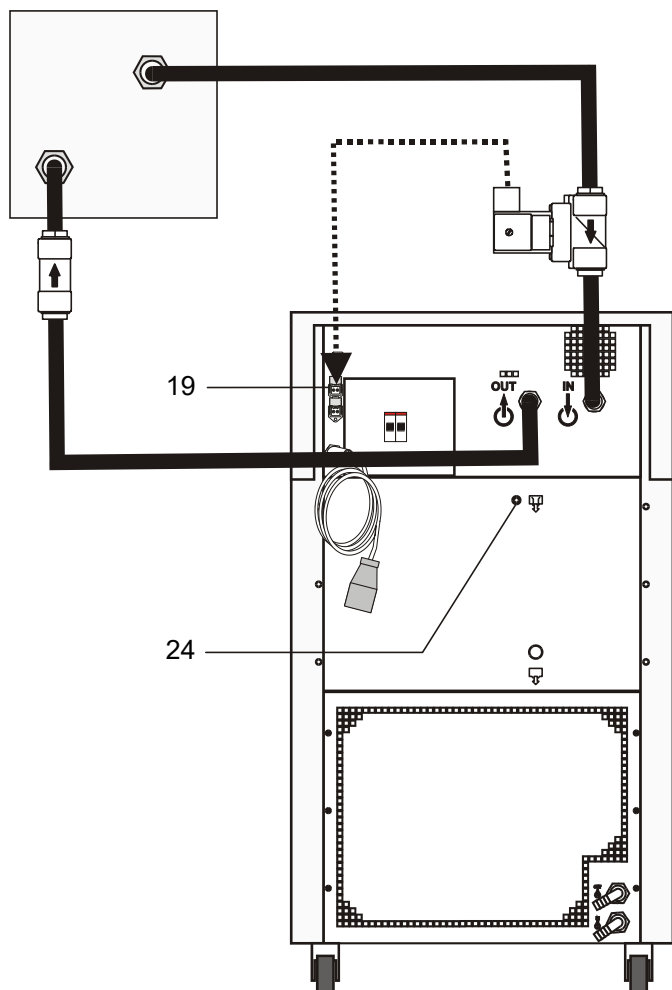
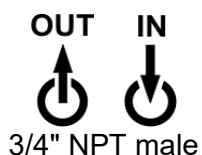

- Connect the tubing for cooling the external system to the pump connectors (22, 23) for feed and return on the rear of the recirculating cooler.
- In case the system to be cooled is located at a higher level than the recirculating cooler, take note of bath liquid flowing back when the unit is switched off. Should the filling volume of the bath tank not be sufficient, prevent the liquid from flowing back by using shut-off valves.



Flood hazard!

For this reason, solenoid valves for loop circuit or shut-off valves can be integrated in the loop circuit.

- ⓘ Connect the valve to the connector (19).

Order No.	Description
8980705	Solenoid valve set 230V/50-60Hz

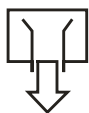

- Unscrew the collar nut from the overflow connector (24). Connect a piece of tubing to the overflow connector and drain into a suitable vessel.
Order-No. 8 970 460 Barbed fitting for tubing 8 mm inner dia.



- If easily volatile temperature liquids are used, as e.g. 3M Fluorinert[®], the overflow should remain closed.

Attention Flood hazard!

Then the level indication (6) should get more attention.



Caution:

Securely attach all tubing to prevent slipping.

5.2.1. Tubing

Recommended tubing:

	Maximum pressure
Textile-reinforced tubing	> 4.5 bar



Warning:

Tubing:

At high working temperatures, the tubing used for temperature control and for the cooling water supply represents a danger source.

A damaged tubing line may allow a large amount of hot bath fluid to be pumped out within a short time.

This may result in:

- Burning of skin
- Breathing difficulties due to hot atmosphere

Safety instructions

- Use suitable connecting tubing.
- Make sure that the tubing is securely attached.
- Avoid sharp bends in the tubing and maintain a sufficient distance from surrounding walls.
- Regularly check the tubing for material defects (e.g., for cracks), at least once a year.
- Preventive maintenance: replace the tubing from time to time.

5.2.2. Bath fluids



Caution:

Carefully read the material safety data sheet of the bath fluid used, particularly with regard to the fire point!

If a bath fluid with a fire point of ≤ 65 °C is used, only supervised operation is possible.

Water:

The quality of water depends on local conditions.

- Due to the high concentration of lime, hard water is not suitable for temperature control because it leads to scale in the bath
- Ferrous water can cause corrosion, even on stainless steel.
- Chlorinated water can cause pitting corrosion.
- Distilled water and deionized water are unsuitable. Their special properties cause corrosion in the bath, even on stainless steel.

Recommended bath fluids:

Bath fluid	Temperature range
soft/decalcified water	5 °C to 80 °C



See JULABO website for list of recommended bath fluids.



Caution:

Fire or other dangers when using bath fluids that are not recommended:

Please contact JULABO before using other than recommended bath liquids.

JULABO assumes no liability for damage caused by the selection of an unsuitable bath fluid.

Unsuitable bath fluids are fluids which, e.g.,

- are highly viscous (much higher than $30 \text{ mm}^2 \times \text{s}^{-1}$ at the respective working temperature)
- have a low viscosity and have creep characteristics
- have corrosive characteristics or
- tend to crack.

No liability for use of other bath fluids!

ATTENTION: The maximum permissible viscosity is $30 \text{ mm}^2/\text{s}$

5.3. Filling



Notice:

- Pay attention to the thermal expansion of bath oil during heating to avoid overflowing of the liquid.

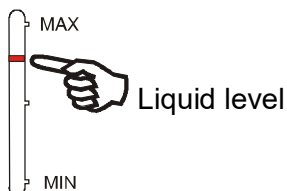

- Connect the tubing from the external system to the pump connectors and check for leaks.
- Check to make sure that the drain port (25) is closed.
- Remove the cap from the filling opening (9).
- Fill the bath tank using a funnel while monitoring the filling level (6).

Filling of the external system.

- Turn the mains switch (1) on
- Press the key  for filling the cooling loop for the external system. **Make sure that air can evacuate from the system.**
- Check the filling level (6) and keep on filling the bath liquid using the funnel.
- After having finished the filling process, the liquid level should be below "MAX".
- Close the filling opening.

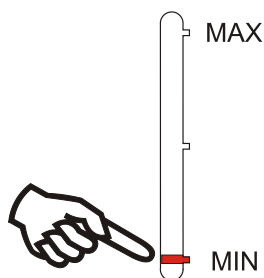

5.4. Draining

**Notice:**

- Do not drain the bath fluid while it is hot or cold! Check the temperature of the bath fluid prior to draining (by switching the unit on for a short moment, for example).
- Store and dispose of the used bath fluid according to the environmental protection laws.

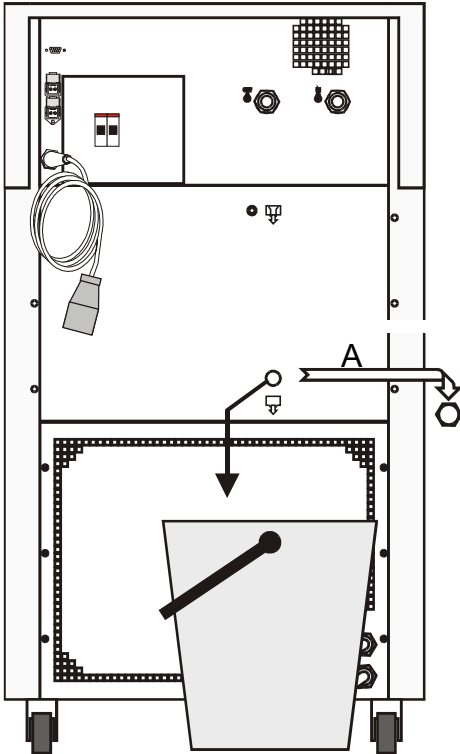

- Turn the mains switch (1) off.
- Place a suitable vessel for accepting the used bath liquid underneath the drain.
- Unscrew the cup nut (A) from the drain port (25) and empty the unit completely.
- Close the drain port.

6. Operating procedures

6.1. Power connection



Caution:

- Only connect the unit to a power socket with an earthing contact (PE – protective earth)!
- The power supply plug serves as a safe disconnecting device from the line and must always be easily accessible.
- Never operate the unit with a damaged mains power cable.
- Regularly check the mains power cables for damage.
- We disclaim all liability for damage caused by incorrect line voltages!

Make sure that the line voltage and frequency match the supply voltage specified on the type plate.

Deviations of $\pm 10\%$ are permissible.

6.2. Switching on / Start - Stop

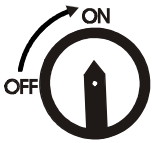

9 5 X X
X X X
X X
P X H X

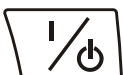

Switching on:

- Turn on the mains power switch (1).

- ① The unit performs a self-test. All segments of the 4-digit MULTI-DISPLAY (LED) and all indicator lights will illuminate. Then the order number (Example: [9501] [026] [03] [P3H1]) and the software version (example: n3.1) of the unit appears. The display „OFF“ or „R OFF“ indicates the unit is ready to operate.

- ① The recirculating cooler enters the operating mode activated before switching the circulator off:
keypad control mode (manual operation, factory setting)
or
remote control mode (operation via personal computer).

Start:

Press the start/stop key. 

The MULTI-DISPLAY (LED) indicates the actual bath temperature. The circulating pump starts with a slight delay.

Stop:

Press the start/stop key. 

The MULTI-DISPLAY (LED) indicates the message "OFF".

6.3. AUTOSTART ON / OFF

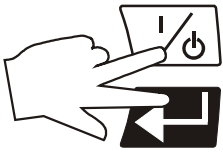

- ① Keep depressed enter  and the start/stop key 
- ② and turn on the circulator with the mains power switch.

For a short while the MULTI-DISPLAY indicates the effective start mode:

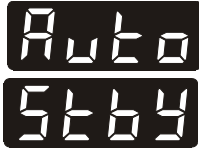

⇒ AUTOSTART on.

⇒ AUTOSTART off.

NOTE:

The recirculating cooler has been configured and supplied by JULABO according to N.A.M.U.R. recommendations. This means for the start mode, that the unit must enter a safe operating state after a power failure (non-automatic start mode). This safe operating state is indicated by „OFF“ or „rOFF“, resp. on the MULTI-DISPLAY (LED). A complete shutdown of the main functional elements such as heater and circulation pump is effected simultaneously.

Should such a safety standard not be required, the AUTOSTART function (automatic start mode) may be activated, thus allowing the start of the circulator directly by pressing the mains power switch or using a timer.



Warning:

For supervised or unsupervised operation with the AUTOSTART function, avoid any hazardous situation to persons or property.

The recirculating cooler does no longer conform to N.A.M.U.R. recommendations.

Take care you fully observe the safety and warning functions of the circulator.

7. Setting the temperatures



Factory settings: 25 °C

Press the key to call up the menu for temperature selection.

Setting can be carried out in the start/stop condition.

Example: Actual value



Setpoint ↓



Actual value ↓



1. Press the key. The setpoint value instead of the actual value is indicated on the display. The value can now be changed.

2. **Change the value:** (Example: 30.0 °C to 65.0 °C)

- Use the cursor keys to move left or right on the display until the numeral you wish to change blinks.
- Use the increase/decrease arrows to change the selected numeral (-, 0, 1, 2, 3, ... 9).

3. Press enter to store the value.

8. Safety installations, warning functions



Check the safety installation at least twice a year! See page 16

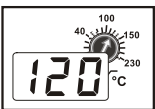

Settings for the excess temperature protection according to IEC 61010-2-010 and for the warning functions for high and low temperature and the conductivity limit

are made in a menu that is called up with the key

8.1. Excess temperature protection



This safety installation is independent of the control circuit. When the temperature of the bath fluid has reached the safety temperature, a complete shutdown of the heater, cooling machine and pump is effected. The alarm is indicated by optical and audible signals (continuous tone) and on the MULTI-DISPLAY (LED) appears the error message "Error 14".

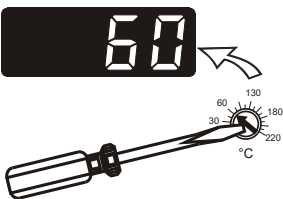

1. Press the key and call up the menu

2. Press enter .

The adjusted cut-out value is indicated on the MULTI-DISPLAY (LED).

3. Set the new cut-out value using a screwdriver via the MULTI-DISPLAY (LED). (Example: 100 °C)

4. Press to update the display immediately.

Recommendation:

Set the excess temperature protection at 5 to 10 °C above the working temperature setpoint.

**Warning:**

The excess temperature protection >SafeTemp< should be set at least below the flash point of the bath fluid used.

There is a risk of fire in the event of a wrong setting!

We disclaim all liability for damage caused by wrong settings!

8.2. Early warning system, low level protection

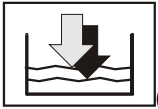

(patented)

This low level protection is independent of the control circuit and is divided in two sections.

1. Switch in stage 1 recognizes a defined fluid level 😊.

An audible warning (interval tone) sounds and on the MULTI-DISPLAY (LED) the message "E 40" appears.

Refill bath fluid!

2. Switch in stage 2 recognizes a low fluid level ☹️.

If stage 2 of the low level protection device (according to IEC 61010-2-010) is triggered, a complete shutdown of the heater and circulating pump is effected.

A continuous alarm tone sounds and a message >CODE 01< appears on the MULTI-DISPLAY (LED).

Turn off the unit with the mains switch, refill bath fluid and turn the unit on again!

E 40

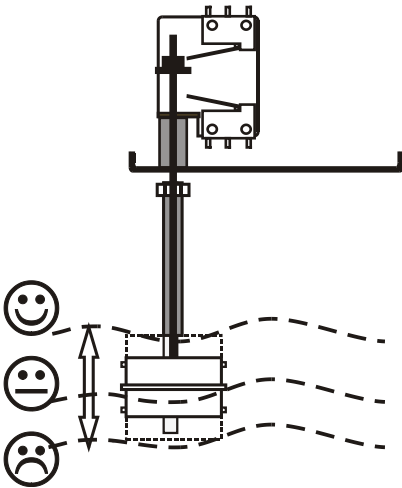

E 01

Important: Check the safety installations from time to time.
See page 16

**Warning:**

When adding bath fluid, always use the same bath fluid type that is already in the bath.

Bath oils must not contain any water and should be pre-heated approximately to the current bath temperature! Explosion hazard at high temperatures!

8.3. High and low temperature warning functions

Factory settings:



High temperature limit
t High 205 °C



Low temperature limit
t Low -55 °C

If for a sensitive temperature application task adherence to a working temperature value (setpoint) is to be supervised, then set high and low temperature warning values.

In the example below, the >Setpoint< of 85 °C is surrounded by the values > t High < 87 °C and > t Low < 83 °C. The electronics immediately registers when the actual temperature attains a temperature out of the limits and it follows a reaction according to what is set in the menu item > Li < (Warning or Alarm).

(see chapter 8.5. Change-over of the warning function to shutdown function).

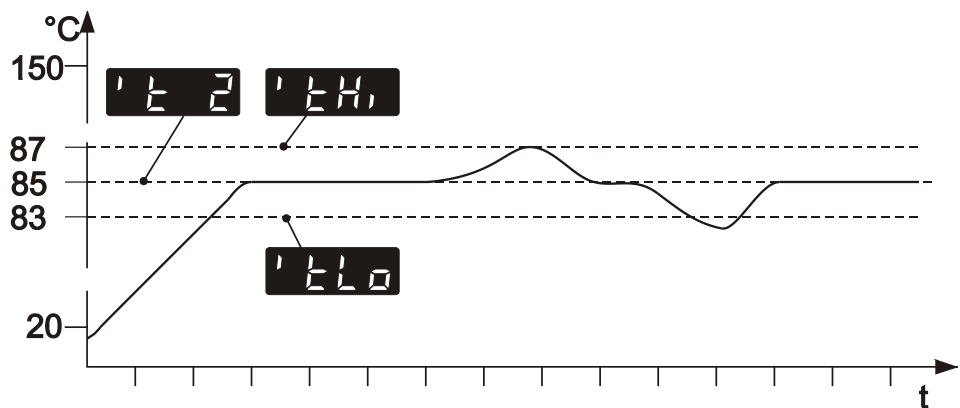

1. Press the key until the menu item or is displayed.
 2. Press enter to indicate the adjusted value on the MULTIDISPLAY (LED) (digit blinks).
 3. Set value:
Use the cursor keys to move left or right on the display until the numeral you wish to change blinks.
Use the increase/decrease arrows to change the selected numeral (-, 0, 1, 2, 3, ... 9).
 4. Press enter to store the selected value.
Press to update the display immediately
- i** The warning functions are only triggered when the actual bath temperature, after start from the „OFF“ or „rOFF“ mode, lies within the set limits for 3 seconds.

Recommendation:

Set the high temperature warning value >t High< 5 °C to 10 °C above the working temperature setpoint

Set the low temperature warning value >t Low< 5 °C to 10 °C below the working temperature setpoint

8.4. Limitation of the operating temperature range

Factory settings:

t 200

t HighSetpoint: 200 °C

t -50

t LowSetpoint: -50 °C



The limitation of the operating temperature range effects the temperature setting under the menu called up with the **T** key. It is possible to adjust only working temperatures that lie within the limit range set here. Existing settings for Setpoint 1, 2, 3 and also for > t High < and > t Low < (see page 26) are automatically deferred within the limit range.

1. Press the key  until the menu item

t 200 or **t** -50 is displayed.

2. Press enter  to indicate the adjusted value on the MULTI-DISPLAY (LED) (digit blinks).

3. Set value:

Use the cursor keys   to move left or right on the display until the numeral you wish to change blinks.

Use the increase/decrease arrows   to change the selected numeral (-, 0, 1, 2, 3, ... 9).

4. Press enter  to store the selected value.

Press **ESC** to update the display immediately.

8.5. Change-over of the warning function to shutdown function



Factory setting: Li 0



For the two menu items > t High < and > t Low < choose between a warning message being signalled or a complete shutdown of the main functional elements such as heater and circulating pump being effected (see page 26).

- Setting >Li / 0<
An audible warning (**interval tone**) sounds and a message appears on the MULTI-DISPLAY (LED).

t High t Low
 or

- Setting >Li / 1<
A complete shutdown of heater and circulating pump is effected. An audible alarm (**continuous tone**) sounds and a message appears on the MULTI-DISPLAY (LED).

t High t Low
 or

t High
High temperature limit

t Low
Low temperature limit

1. Press the key until the menu item is displayed.
2. Press enter to indicate the adjusted parameter on the MULTI-DISPLAY (LED) (digit blinks).
3. Select the parameter with the keys (0 / 1).
4. Press enter to store the selected parameter.
Press to update the display immediately.

9. Menu functions

MENU

➤ Pump

➤ ATC

➤ Remote

➤ Baudrate

➤ Handshake

➤ Parity

➤ XP

➤ Tn

➤ Tv

➤ Reset

The term „menu functions“ refers to adjustments such as

- electronically adjustable pump capacity

- ATC - Absolute Temperature Calibration

ATC status

Type (Art): >1. point<, >2. point < or >3. point < calibration

2 values per calibration point

ttx = Defined temperature value of the calibration point.
This value is automatically stored with >Ctx< and can be indicated for control purposes.

Ctx = The „Calibration value“ is determined with a temperature measuring device and stored under menu item > Ctx <.

- Online communication, with adjustable interface parameters

- PID temperature control, control parameters

- Factory setting

9.1. Setting the pump pressure



Factory setting:
Stage 2



The pressure of the circulating pump is adjustable in stages.

See table 1 page 9

1. Press the **MENU** button until the menu item is displayed.
2. Press enter to indicate the parameter.
3. Select the parameter with the keys (1 ... 2).
4. Press enter to store the selected parameter.
Press **ESC** to update the display immediately.

9.2. ATC Absolute Temperature Calibration, 3-point calibration

ATC serves to compensate a temperature difference that might occur between circulator and a defined measuring point in the bath tank because of physical properties.

Examples:

1-point calibration

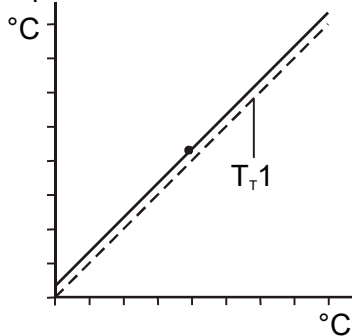

3-point calibration

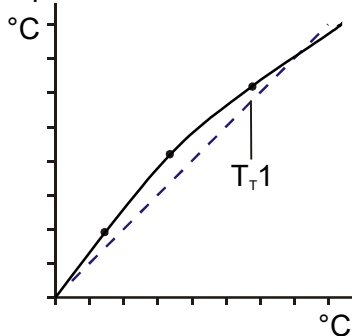

$T_T 1$ = Original curve

Principle:

For ATC calibration, in steady state the bath temperature at the location of the temperature sensor (T_M) is determined at the respective adjusted working temperature. This value is then set on the circulator in the menu >ATCalibration< under menu item >Calwert X<.

This can be a 1-point, 2-point or 3-point calibration.

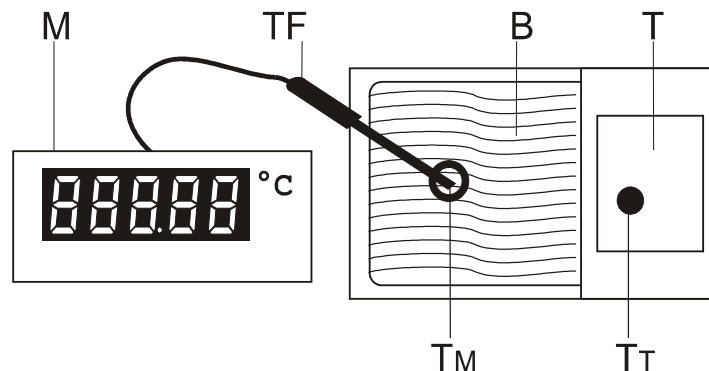

M = Temperature measuring instrument with temperature sensor (TF)

B = Bath tank with T = circulator

T_M = Temperature on measuring point

T_T = Temperature on circulator



The menu ATC - Absolute Temperature Calibration is structured in 2 levels.

ATC status
Calibration type: 1-, 2-, 3-point calibration

2 values per calibration point
 ttx = Temperature indication on circulator
 Indicates the value of the calibration point entered last.
 Ctx = Calibration temperature x
 Input of the new value for the calibration curve.

Examples:
 $T_T = 80.0\text{ }^\circ\text{C}$
 $T_M = 79.7\text{ }^\circ\text{C}$

$T_T = 120.0\text{ }^\circ\text{C}$
 $T_M = 119.5\text{ }^\circ\text{C}$

$T_T = 160.0\text{ }^\circ\text{C}$
 $T_M = 159.3\text{ }^\circ\text{C}$

Example: 3-point calibration

In the temperature range of 80 °C to 160 °C the calibration curve of the temperature sensor (T_T) should be assimilated to the actual temperatures on the measuring point (T_M).

1. Calibration procedure:

Press **T** and set the first temperature value under e.g. **t1** for example (example 1st value = 80 °C).

2. Wait until this temperature is maintained constant in the bath for about 5 minutes.

3. Call up the >ATC< menu:

Press the **MENU** button until the menu item **Atc** is displayed and press enter **↵** to switch to menu level 2.

4. Adjusting menu item >ATC Status<:

Press enter **↵** and indicate the parameter. Select the parameter with the keys **▼ ▲** (no / YES). Press enter **↵** to store the selected parameter.

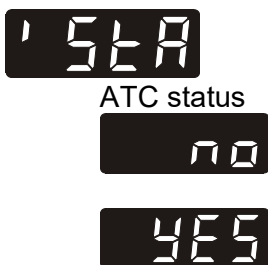

Factory setting: YES

>no< During the calibration process **>no<** needs to be set.

Continue: Press the **MENU** button to call up the menu item **>Art<**.

>YES< The controller of the circulator uses the new calibration curve. Set this parameter after the calibration process.

Continue: Press **ESC** to quit the menu.



Example



5. Determine the calibration type:

(1-point, 2-point or 3-point calibration.)

Press the button until the menu item is displayed and press enter to indicate the parameter.

Select the parameter with the keys (1, 2, 3).

Press enter to store the selected parameter.

i Depending on which calibration type is selected (1-point, 2-point or 3-point calibration) only the necessary menu items are indicated.

For 1-point calibration: >tt1< and >Ct1<

For 2-point calibration: >tt1< and >Ct1<
>tt2< and >Ct2<

For 3-point calibration: >tt1< and >Ct1<
>tt2< and >Ct2<
>tt3< and >Ct3<

6. Setting and storing the value:

Press the button until the menu item

is displayed and press enter to open the input window.

Read the value of T_M on the temperature measuring device and enter the respective value.

Use the cursor keys to move left or right on the display until the numeral you wish to change blinks.

Use the increase/decrease arrows to change the selected numeral (-, 0, 1, 2, 3, ... 9).

Press enter and the circulator also stores the value of T_r

as value for (80.00 °C).

The first of the 3 points is now calibrated.

i The values for >ttx< can only be displayed, but they cannot be modified.

7. Repeat the calibration procedure for 120 °C and 160 °C.

Store the values under or resp.

Notice:

In the ATC status > YES<, the ATC calibration curve always affects the effective working temperature (also the one set via the interface).

From example on page 31 for $T_M = Ctx$



9.3. Remote control: activate – deactivate



The circulator is to be prepared for remote control by a personal computer via the serial interface RS232: Set the menu item >remote< from >no< to >YES<.

Factory setting: no



1. Press the button until the menu item is displayed.
2. Press enter to indicate the parameter.
3. Select the parameter with the keys (YES/no).
4. Press enter to store the selected parameter.

>no< No remote control via RS232

>YES<

Continue: Press to quit the menu.

The display changes from



keypad control mode (manual operation) to



remote control mode (operation via personal computer).

9.4. Interface - Baud rate, Handshake, Parity

Factory settings:

4.8 kBauds

2 = even

Hardware handshake

To allow communication of the circulator with a PC or a superordinated process control system take care the interface parameters of both units match.

Adjustable interface parameters



Example: 4.8 kbauds



Baud rate 4.8 = 4800 bauds
 9.6 = 9600 bauds



Example: 2 = even



Parity 0 = no Parity
 1 = odd
 2 = even







Handshake

0 = Xon/Xoff protocol software handshake
1 = Protocol RTS/CTS hardware handshake



Data bits = 7; Stop bits = 1

1. Press the  button until the desired menu item is displayed.
2. Press enter  to indicate the parameter.
3. Select the parameter with the keys  .
4. Press enter  to store the selected parameter.

9.5. Control parameters – Xp, Tv, Tn

The control parameters preset in factory are in most cases adequate for achieving an optimum temperature pattern for the samples requiring temperature application.

Each parameter may be manually set via the keypad if necessary, to allow optimum control performance.



Setting range:
0.1 ... 99.9

Proportional range >Xp<

The proportional range is the range below the selected temperature value in which the control circuit reduces the heating power from 100 % to 0 %.



Setting range:
1 ... 9999

Resetting time >Tn< (Integral component)





Compensation of the remaining control deviation due to proportional regulation. An insufficient resetting time may cause instabilities to occur. Excessive resetting time will unnecessarily prolong compensation of the control difference.





Setting range:
0 ... 99

Lead time >Tv< (Differential component)

The differential component reduces the control settling time. An insufficient lead time will prolong the time required to compensate for disturbance effects and cause high overshooting during run-up. An excessive lead time could cause instabilities (oscillations) to occur.

1. Press the  button until the desired menu item is displayed.
2. Press enter  to indicate the parameter.
3. Set value:
 Use the cursor keys   to move left or right on the display until the numeral you wish to change blinks.

 Use the increase/decrease arrows   to change the selected numeral (-, 0, 1, 2, 3, ... 9).
4. Press enter  to store the selected value.

Optimization instructions for the PID control parameters:

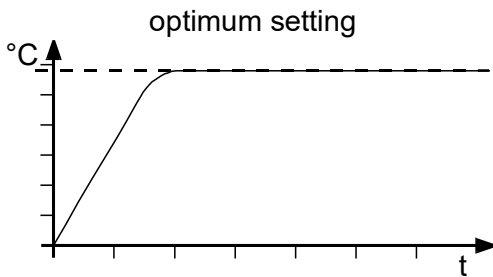

The heat-up curve reveals inappropriate control settings.

Inappropriate settings may produce the following heat-up curves:

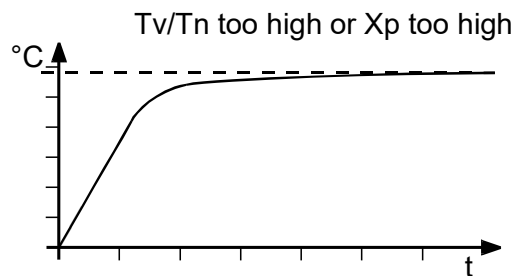
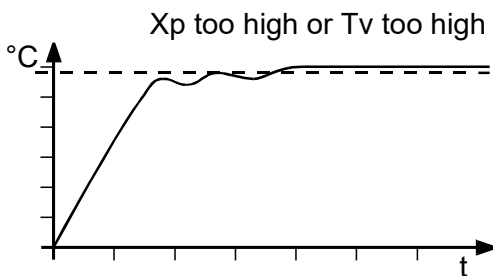
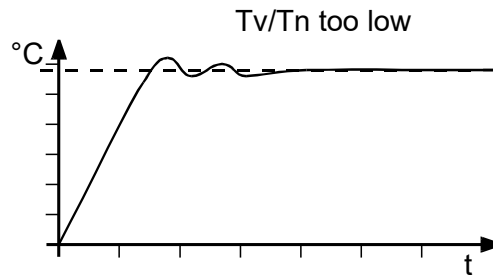
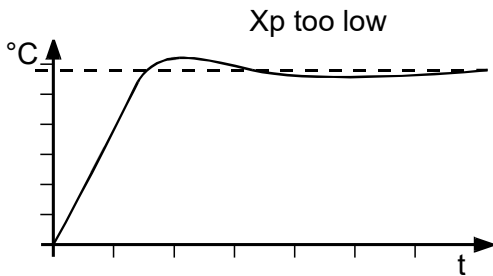

9.6. Reset



Use this to reset all values to factory setting.

Factory setting: no



1. Press the button until the menu item is displayed.
2. Press enter to indicate the parameter (no).
3. Press the keys to select the parameter (YES).
4. Press enter to confirm the reset.
After the reset is carried out, the parameter is automatically set to >no<.

10. Troubleshooting guide / Error messages



Alarm with a complete shutdown of the unit

Whenever the microprocessor electronics registers a failure, a complete shutdown of the heater and circulating pump is performed. The alarm light

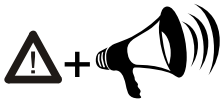

„“ illuminates and a continuous signal tone sounds. The MULTI-DISPLAY (LED) indicates the cause for the alarm in form of a code.



Warning without a complete shutdown of the unit

The MULTI-DISPLAY (LED) indicates the cause for the warning in form of a code and an acoustic signal sounds in regular intervals. These messages appear every 10 seconds.



Press enter to quit the audible signal.



- The circulator is operated without bath fluid, or the liquid level is insufficient. Replenish the bath tank with the bath fluid.
- Tube breakage has occurred (insufficient filling level due to excessive bath fluid pumped out). Replace the tubing and replenish the bath tank with the bath fluid.
- The float is defect (e. g., because damaged in transit). Repair by authorized JULABO service personnel.
- Excess temperature sensors defect.
- The excess temperature value lies below the working temperature setpoint. Set the excess temperature to a higher value.



- Excess temperature warning or Excess temperature alarm with a complete shutdown of the main functional elements being effected.
Warn type: >Li 0 = Warning< or > Li 1 = Alarm<



- Low temperature warning or Low temperature alarm with a complete shutdown of the main functional elements being effected.
Warn type: >Li 0 = Warning< or > Li 1 = Alarm<



- Cable of the working temperature sensor interrupted or short-circuited.



- Defect of the working or excess temperature sensor. Working temperature and excess temperature sensors report a temperature difference of more than 35 K.



- Other errors (I²C-BUS errors)



- Error in A/D converter



- Excess temperature sensors defect.
- The excess temperature value lies below the working temperature setpoint. Set the excess temperature to a higher value.



- Cable of the excess temperature sensor interrupted or short-circuited.



- The early warning system for low level signals a critical fluid level. Replenish the bath tank with the bath fluid.

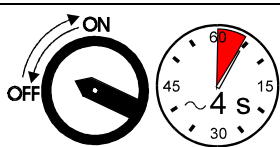

- **A** After eliminating the malfunction, press the mains power switch off and on again to cancel the alarm state.
If the unit cannot be returned to operation, contact an authorized JULABO service station.



Mains fuses

The mains fuses on the rear of the unit are safety cutouts – 16A.

11. Electrical connections



Notice:

Use shielded cables only.
 The shield of the connecting cable is electrically connected to the plug housing.
 The unit ensures safe operation if connecting cables with a maximum length of 3 m are used. The use of longer cables does not affect proper performance of the unit, however external interferences may have a negative impact on safe operation.

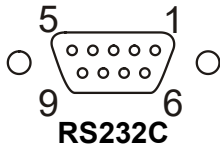

RS232 serial interface

This port can be used to connect a computer with an RS232 cable for remote control of the circulator.

Pin assignments RS232:

Pin 2	RxD	Receive Data
Pin 3	TxD	Transmit Data
Pin 5	0 V	Signal GND
Pin 7	RTS	Request to send
Pin 8	CTS	Clear to send

Pin 1; 4; 6, 9 Reserved - do not use!

Accessories:	Order No.	Description
	8 980 073	RS232 interface cable 9-pol./9-pol. , 2,5 m
	8 900 110	USB interface adapter cable

Control connector

Return flow safety device.

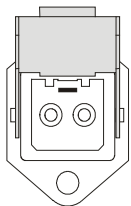

If the liquid levels in the recirculating cooler and the external system are at different heights, overflowing must be prevented after the power has been turned off. For this reason, solenoid valves for loop circuit can be integrated in the loop circuit.

- ⓘ The control output is not powered in the OFF condition.
 Output voltage: 230 V~ / max. 0.1 A

12. Remote control

12.1. Setup for remote control

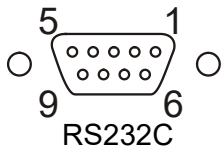

- Check the interface parameters for both interfaces (on circulator and PC) and make sure they match.
(Serial interface - see page 33)
- Set the menu item >Remote< from >no< to >YES<.
(see page 33).
- Connect both units with an interface cable.



Like all parameters which can be entered through the keypad, interface parameters are stored in memory even after the circulator is turned off.

12.2. Communication with a PC or a superordinated data system

If the recirculating cooler is put into remote control mode via the configuration level, the VFD COMFORT-DISPLAY will read „R -OFF-„ = REMOTE STOP. The recirculating cooler is now operated via the computer. In general, the computer (master) sends commands to the recirculating cooler (slave). The recirculating cooler sends data (including error messages) only when the computer sends a query.



In remote control mode: After a power interruption the order to start and all values which have to be adjusted must be resent from the personal computer via the interface.
AUTOSTART is not possible.

A transfer sequence consists of:

- command
 - space (↔; Hex: 20)
 - parameter (the character separating decimals in a group is the period)
 - end of file (↵; Hex: 0D)
- The response (data string) after an **in** command is always followed by a line feed (LF, Hex: 0A).

The commands are divided into **in** or **out** commands.

in commands: asking for parameters to be displayed

out commands: setting parameters



Important times for a command transmission:

To ensure a safe data transfer, the time gap between two commands should be at least 250 ms.

The circulator automatically responds to an **in** command with a data string followed by a LF (Line Feed). The next command should only be sent after 10 ms.



The **out** commands are valid only in remote control mode.

Examples:

Command to set the working temperature >Setpoint1< to 55.5 °C

out_sp_00 ↔ 55.5↵

Command to ask for the working temperature >Setpoint1<

in_sp_00↵

Response from the circulator:

55.5↵ LF

12.3. List of commands

out commands: Setting parameters or temperature values.

Command	Parameter	Response of circulator
out_mode_05	0	Stop the unit = R –OFF–.
out_mode_05	1	Start the unit.
out_sp_00	xxx.xx	Set working temperature. „t“
out_sp_03	xxx.xx	Set high temperature warning limit „t High“
out_sp_04	xxx.xx	Set low temperature warning limit „t Low“
out_sp_07	x	Set the pump pressure stage. (1 ... 3)
out_par_06	xxx	Xp control parameter of the internal controller.
out_par_07	xxx	Tn control parameter of the internal controller.
out_par_08	xxx	Tv control parameter of the internal controller.

in commands: Asking for parameters or temperature values to be displayed.

Command	Parameter	Response of circulator
version	None	Number of software version (V X.xx)
status	none	Status message, error message (see page 42)
in_pv_00	none	Actual bath temperature.
in_pv_01	none	Heating power being used (%).
in_pv_03	none	Temperature value registered by the safety sensor.
in_pv_04	none	Setpoint temperature („SafeTemp“) of the excess temperature protection
in_sp_00	none	Working temperature „t 1“
in_sp_03	none	High temperature warning limit „t High“
in_sp_04	none	Low temperature warning limit „t Low“
in_sp_07	none	Pump pressure stage
in_par_00	none	Temperature difference between working sensor and safety sensor
in_par_01	none	Te - Time constant of the external bath.
in_par_02	none	Si - Internal slope
in_par_06	none	Xp control parameter of the internal controller.
in_par_07	none	Tn control parameter of the internal controller.
in_par_08	none	Tv control parameter of the internal controller.
in_mode_05	none	Circulator in Stop/Start condition: 0 = Stop 1 = Start

12.4. Status messages

Status messages	Description
00 MANUAL STOP	Recirculating cooler in „OFF“ state.
01 MANUAL START	Recirculating cooler in keypad control mode.
02 REMOTE STOP	Recirculating cooler in „r OFF“ state.
03 REMOTE START	Recirculating cooler in remote control mode.

12.5. Error messages

Error messages	Description
-01 LOW LEVEL ALARM	Low liquid level alarm or Excess temperature protector alarm
-03 EXCESS TEMPERATURE WARNING	High temperature warning.
-04 LOW TEMPERATURE WARNING	Low temperature warning.
-05 WORKING SENSOR ALARM	Working temperature sensor short-circuited or interrupted.
-06 SENSOR DIFFERENCE ALARM	Sensor difference alarm. Working temperature and safety sensors report a temperature difference of more than 35 K.
-07 I²C-BUS ERROR	Internal error when reading or writing the I ² C bus.
-08 INVALID COMMAND	Invalid command.
-09 COMMAND NOT ALLOWED IN CURRENT OPERATING MODE	Invalid command in current operating mode.
-10 VALUE TOO SMALL	Entered value too small.
-11 VALUE TOO LARGE	Entered value too large.
-12 TEMPERATURE MEASUREMENT ALARM	Error in A/D converter.
-13 WARNING : VALUE EXCEEDS TEMPERATURE LIMITS	Value lies outside the adjusted range for the high and low temperature warning limits. But value is stored.
-14 EXCESS TEMPERATURE PROTECTOR ALARM	Excess temperature protector alarm 
-15 EXTERNAL SENSOR ALARM	External control selected, but external Pt100 sensor not connected.
-33 SAFETY SENSOR ALARM	Excess temperature sensor short-circuited or interrupted.
-40 NIVEAU LEVEL WARNUNG	Low liquid level warning in the internal reservoir.

13. JULABO Service – Online remote diagnosis

JULABO circulators of the HighTech series are equipped with a black box. This box is implemented in the controller and records all significant data for the last 30 minutes.

In case of a failure, this data can be read out from the unit by using special software. This software is available as a free download from www.julabo.com.

- Installation is easy and is performed step by step. Please observe the instructions.
- Data read-out is possible in the conditions “OFF”, “R OFF” or “ALARM”.
- Connect the circulator to the computer using an interface cable.
- Start the EasyBlackBox program. The program asks for the port used (COM1,) and the baud rate of the unit. You do not have this information on hand? Simply try it out! The program continues to send the request until the correct settings are made.

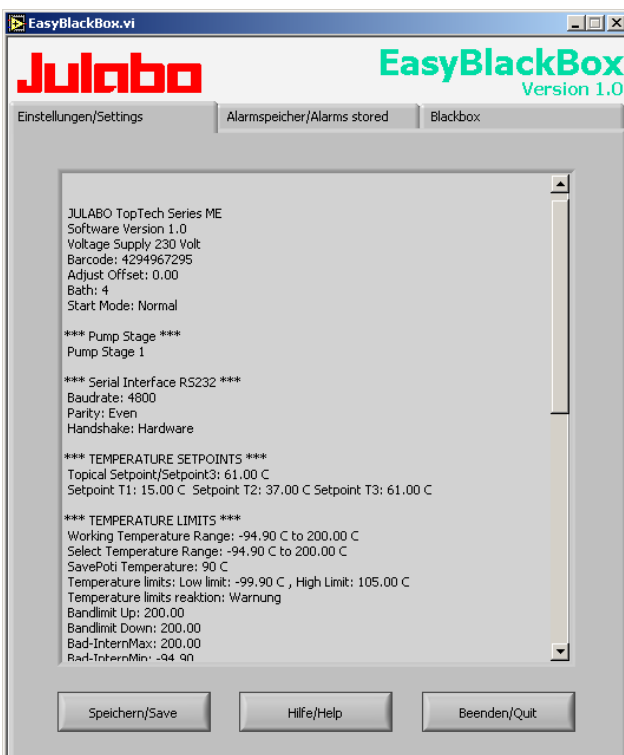

- Data is read out and shown on the monitor divided in the sections >Einstellungen/Settings<, >Alarmspeicher/Alarms stored<, >Blackbox<
- ← see example
- After pressing >Speichern/Save< a text file is compiled. The program proposes a filename - >C:\model description and barcode no.<. Modifications are possible.
- E-mail this file to Service@Julabo.us, JULABO's service department. JULABO is thus able to provide rapid support.

14. Cleaning / repairing the unit



Caution:

- Always turn off the unit and disconnect the mains cable from the power source before cleaning the unit.
- Prevent humidity from entering into the circulator.
- Service and repair work may be performed only by authorized electricians.

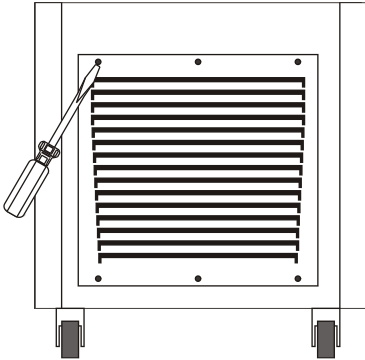

Air cooled recirculating coolers:

To maintain the full cooling performance, clean the condenser from time to time.

- Switch off the unit, disconnect mains power cable.
- Remove the venting grid.
- Clean the ribbed condenser with a vacuum cleaner.
- Replace the venting grid.
- Switch on the unit.

Cleaning:

For cleaning the bath tank and the immersed parts of the recirculating cooler, use low surface tension water (e.g., soap suds). Clean the outside of the unit using a wet cloth and low surface tension water.

The recirculating cooler is designed for continuous operation under normal conditions. Periodic maintenance is not required.

The tank should be filled only with a bath fluid recommended by JULABO. To avoid contamination, it is essential to change the bath fluid from time to time.

Repairs

Before asking for a service technician or returning a JULABO instrument for repair, please contact an authorized JULABO service station.

JULABO Technical Service

Tel.: +1(610) 231-0250 Option 3

Fax: +1(610) 231-260

Email: Service@julabo.us

When returning the unit:

- Clean the unit in order to avoid any harm to the service personnel.
- Attach a short fault description.
- During transport the unit has to stand upright. Mark the packing correspondingly.
- When returning a unit, take care of careful and adequate packing.
- JULABO is not responsible for damages that might occur from insufficient packing.



JULABO reserves the right to carry out technical modifications with repairs for providing improved performance of a unit.

15. WARRANTY PROVISIONS

The following Warranty Provisions shall apply to products sold in North America by Julabo ("Seller") to the entity shown as buyer ("Buyer") on Seller's invoice.

Initial Warranty

Upon Seller's receipt of payment in full for the products and subject to Buyer's compliance with the terms of sale and any other agreement with Seller relating to the products, Seller warrants to the Buyer that the products manufactured by the Seller are free from defects in material and workmanship for a period not to exceed two (2) years of operation from the date the product is shipped by Seller to Buyer (the "Initial Warranty").

EXCLUSION OF ALL OTHER EXPRESS WARRANTIES; EXCLUSION OF ALL IMPLIED WARRANTIES.

OTHER THAN THE INITIAL WARRANTY, NO OTHER EXPRESS WARRANTIES ARE MADE. ALL IMPLIED WARRANTIES OF EVERY TYPE AND KIND, INCLUDING BUT NOT LIMITED TO ANY IMPLIED WARRANTY OF MERCHANTABILITY OR FITNESS FOR A PARTICULAR PURPOSE OR USE, ARE EXCLUDED IN ALL RESPECTS AND FOR ALL PURPOSES. SELLER DISCLAIMS AND MAKES NO IMPLIED WARRANTIES WHATSOEVER.

Exclusions

The Initial Warranty does not include damage to the product resulting from accident, misuse, improper installation or operation, unauthorized or improper repair, replacement or alteration (including but not limited to repairs, replacements, or alterations made or performed by persons other than Seller's employees or authorized representatives), failure to provide (or use of improper) maintenance, unreasonable or unintended use or abuse of the product, or failure to follow written installation or operating instructions.

Buyer must return the product's record of purchase to the Seller or one of Seller's authorized representatives within thirty (30) days of the date the product is shipped by Seller to Buyer in order to make a claim under the Initial Warranty. Notwithstanding anything contained herein to the contrary, all glassware, including but not limited to reference thermometers, are expressly excluded from the Initial Warranty.

Buyer's sole remedies; Limitations on Seller's Liability

Buyer's sole and exclusive remedy under the Initial Warranty is strictly limited, in Seller's sole discretion, to either: (i) repairing defective parts; or (ii) replacing defective parts. In either case, the warranty period for the product receiving a repaired or replaced part pursuant to the terms of the Initial Warranty shall not be extended. All repairs or replacements performed by Seller pursuant to these Warranty Provisions shall be performed at one of the Seller's facility in Allentown, Pennsylvania, U.S.A. or at the facility of an authorized representative of Seller, which location shall be determined by Seller in its sole discretion; provided, however, that Seller may, in its sole discretion perform such repairs or replacements at Buyer's facility in which case Buyer shall pay Seller's travel, living and related expenses incurred by Seller in performing the repairs or replacements at Buyer's facility. As a condition precedent to Seller's obligation to repair or replace a product part under the Initial Warranty, Buyer shall (i) promptly notify Seller in writing of any such defect; (ii) shall have returned the product's record of purchase to Seller or to Seller's authorized representatives within thirty (30) days of the date the product is shipped by the seller; and (iii) assist Seller in all respects in its attempts to determine the legitimacy and basis of any claims made by or on behalf of Buyer including but not limited to providing Seller with access to the product to check operating conditions. If Buyer does not provide such written notice to Seller within the Initial Warranty period or fails to return the product's record of purchase as set forth above, Seller shall have no further liability or obligation to Buyer therefor. In no event shall Seller's liability under the Initial Warranty exceed the original purchase price of the product which is the subject of the alleged defect.

THE REMEDIES PROVIDED IN THE INITIAL WARRANTY ARE THE SOLE AND EXCLUSIVE REMEDIES AVAILABLE TO THE BUYER. NOTWITHSTANDING ANYTHING TO THE CONTRARY CONTAINED HEREIN,

WARRANTY PROVISIONS

AND EVEN IF THE SOLE AND EXCLUSIVE REMEDIES FAIL OF THEIR ESSENTIAL PURPOSE FOR ANY REASON WHATSOEVER, IN NO EVENT SHALL SELLER BE LIABLE FOR BUYER'S MANUFACTURING COSTS, LOST PROFITS, GOODWILL, OR ANY OTHER SPECIAL, INDIRECT, PUNITIVE, INCIDENTAL OR CONSEQUENTIAL DAMAGES TO BUYER OR ANY THIRD PARTY AND ALL SUCH DAMAGES ARE HEREBY DISCLAIMED.

Assignment

Buyer shall not assign any of its rights or obligations hereunder without the prior written approval of Seller; provided, however, that if Buyer is a distributor of Seller, the rights and obligations of Buyer under these Warranty Provisions shall inure to the benefit of and be binding upon Buyer's customers who provide the product's proof of purchase to Seller pursuant to the terms set forth herein. Seller may assign any or all of its rights or obligations hereunder without Buyer's prior consent.

Governing Law

The Warranty Provisions and all questions relating to their validity, interpretation, performance, and enforcement shall be construed in accordance with, and shall be governed by, the substantive laws of the Commonwealth of Pennsylvania without regard to its principles of conflicts of law.

Waiver

Any failure of the part of Seller to insist on strict compliance with the Warranty Provisions shall no way constitute a waiver of such right. No claim or rights arising out of a breach of the Warranty Provisions by Buyer may be discharged in whole or in part by a waiver of the claim or right, unless the waiver is in writing signed by an authorized representative of Seller. Seller's waiver or acceptance of any breach by Buyer of any provisions of the Warranty Provisions shall not constitute a waiver of or an excuse for nonperformance as to any other provision of the Warranty Provisions nor as to any prior or subsequent breach of the same provision.

Freight

Seller will arrange and pay for shipping and handling for the return of the unit to the Buyer.

Out of Box Failure (OBF)

An Out of Box Failure (OBF) is defined as a product failure immediately following unpacking and installation of a newly delivered product. JULABO provides a 14-day grace period after the date of shipment, during which time the delivered product must be checked for defect. The same exclusions that apply to the regular warranty also apply to OBF classification. For example, JULABO will not be liable for transport damage, damage inflicted by the customer or any other party, or defects arising from improper installation or usage.