

IC50E



Immersion cooler IC50E

Translation of the original operating manual

30005985.A

05/2025

US

Legal

USA Office:

JULABO USA, Inc.
884 Marcon Boulevard
Allentown, PA 18109
Phone: +1(610) 231-0250
Info@julabo.us
www.julabo.us

Headquarter:

JULABO GmbH
Gerhard-Juchheim-Strasse 1
77960 Seelbach
Germany

The content of this operating manual is protected by copyright. Information, including texts, images, and other contents may not be reproduced, distributed, transmitted, stored or otherwise used in any form without prior explicit written consent.

Illustrations in this operating manual are for illustrative purposes and are not necessarily displayed to scale.

1	Foreword	5
2	About this manual	6
2.1	Warnings	6
2.2	Symbols used	7
3	Intended use	8
4	Safety	9
4.1	General Safety Instructions for the operating company	9
4.2	Safety instructions	10
4.3	Safety symbols	12
5	Product description	13
5.1	Function description	13
5.2	Functionality of the temperature control.....	13
5.3	Operating and functional elements	14
5.4	Interfaces.....	17
5.4.1	USB-C interface	17
5.4.2	Connection of Pt100 temperature sensor	18
5.5	Operating interface.....	19
5.5.1	Softkeys and status icons	19
5.6	Main menu.....	21
5.6.1	Adjust safety menu.....	21
5.6.2	'Evaluate data' menu.....	21
5.6.3	Install unit menu	22
5.6.4	Settings menu	22
5.6.5	Service menu	22
5.6.6	Menu About.....	22
5.7	Alarm messages.....	23
5.8	Technical data	24
5.8.1	Refrigerant.....	25
6	Transport and installation	26
6.1	Unpacking the device	27
6.2	Transporting the device.....	27
6.3	Install the device at the operating location	27
7	Initial operation	28

7.1	Attach safety signs	28
7.2	Immerse the cooling probe in the medium	29
7.3	Connect the device to the power supply	30
8	Operation	31
8.1	Switch on the unit	31
8.2	Switch off the unit	31
8.3	Configuring setpoint temperature	32
8.4	Start temperature control application	32
8.5	Activate autostart function	33
8.6	Record data	33
9	Maintenance	34
9.1	Replace detachable power cord	34
9.2	Check safety symbols.....	34
9.3	Clean device	36
9.4	Cleaning condenser.....	36
9.5	Device storage.....	38
9.6	Technical Service	38
9.7	Warranty	39
10	Disposal	42
10.1	Device disposal	42
11	Appendix	43
11.1	Alarms and Warnings	43

1 Foreword

Congratulations!

You have made an excellent choice.

JULABO would like to thank you for the trust you have placed in our company and products.

This operating manual will help you become acquainted with the use of our units. Read the operating manual carefully. Keep the operating manual handy at all times.

2 About this manual

This manual is intended for the equipment specified on the cover page.

	NOTE
	Observe the safety instructions! Read the Safety section of this manual before using the equipment for the first time.

2.1 Warnings

The manual contains warnings to increase safety when using the device. Warnings must always be observed.

A warning sign displayed in signal color precedes the signal word. The signal word, highlighted in color, specifies the severity of the hazard.

	DANGER
	This signal word designates a danger with a high level of risk which, if it not prevented, will result in death or serious injuries.

	WARNING
	This signal word designates a danger with a medium level of risk which, if it not prevented, may result in death or serious injuries.

	CAUTION
	This signal word designates a danger with a low level of risk which, if it not prevented, may result in minor to moderate injuries.

	NOTE
	This signal word designates a possibly harmful situation. If it is not avoided, the system or objects in its vicinity may be damaged.

2.2 Symbols used

Various symbols are used throughout this manual to aid reading comprehension. This list describes the symbols used.

- ✂ Tools needed for the following approach
- ▶ Prerequisite to be met for the following procedure
- 1. Numbered action steps
- ↪ Interim result for individual action steps
- ✎ Additional note for individual action steps
- ✓ Final result of a procedure
- <> Terms in angle brackets denote control menu
- [] Terms in square brackets denote keys, softkeys and buttons

3 Intended use

This section defines the purpose of the unit so that the operator can operate the unit safely and avoid misuse.

The JULABO IC50E immersion cooler is used for cooling liquids, e.g. in Dewar flasks, beakers or other vessels in conjunction with heating circulators, for continuous counter-cooling or as a substitute for dry ice.

Only use the device if it is in technically perfect condition and only use it in accordance with its intended use. Be aware of safety issues or hazards and comply with the operating manual! In particular, always correct malfunctions that could affect safety immediately!

The device is not suitable for direct temperature control application of food, other consumables or pharmaceutical or other medical products.

The device is not suitable for use in an explosive environment.

4 Safety

4.1 General Safety Instructions for the operating company

This section outlines the General Safety Instructions that must be observed by the operator to ensure safe operation.

- The operator is responsible for the qualifications of its operating personnel.
- The operator must ensure that the operating personnel has been instructed in use of the device.
- The device operators must receive regular training about the dangers involved in their work and measures to prevent such dangers.
- The operator must ensure that persons entrusted with the operation, installation and maintenance have read and understood the operating manual.
- The device may only be configured, installed, maintained and repaired by trained personnel with appropriate qualifications.
- If hazardous substances or substances that may become hazardous are used, the device may only be used by personnel who are qualified to handle these substances and the device.
- The operator must ensure that the device is checked for safety and functionality at regular and usage-related intervals.
- The operator must ensure that the mains supply has a low impedance to prevent influencing other devices powered by the same supply.

Staff qualifications:

Technical staff is understood to be a person who successfully completed vocational training. They must assess assigned work and be able to independently recognize and avoid possible dangers based on their specialist training and work experience.

4.2 Safety instructions

The unit is built in accordance with state of the art technology and recognized safety regulations. Despite this, its use may pose a risk to life and limb for the user or third parties.

Therefore, always read and observe the following safety instructions before using the product.

Use other than for the intended purpose!

If the device is used for purposes other than those intended by the manufacturer, the protection afforded by the device may be impaired.

Cooling probe / probe hose

The cooling probe and the probe hose become extremely cold during operation. There is a risk of frostbite.

Only switch on the appliance after the probe has been properly placed in the container for cooling.

Wear suitable gloves and safety goggles.

Do not touch the probe when it is iced up!

Electric shock from electrical system!

Touching damaged live parts can cause severe electric shocks and lead to injury or even death.

- Have damaged insulation and parts of the electrical system immediately repaired by JULABO service technicians or a qualified specialist workshop
- Immediately replace damaged power cords
- When connected with a mains plug, this mains plug must always be readily accessible

Natural refrigerants are flammable!

The unit contains flammable refrigerant in a permanently sealed circuit. If there is a leak in the refrigerant cycle, a flammable concentration may form in the air and ignite or explode. This can result in serious injury or death.

- Use the required minimum room size for operating the unit.
- If refrigerant leaks, stop the unit immediately and ventilate the room thoroughly.
- Have damage to the refrigerant cycle repaired only by JULABO service technicians or qualified specialists.
- Have maintenance work performed only by JULABO service technicians or qualified specialists.
- Nationally applicable standards and guidelines must be observed.

Refrigerants are harmful to health!

Refrigerants and their vapors are harmful to health. There is a suffocation risk in enclosed spaces.

- Do not touch or inhale refrigerants.
- Have damage to the refrigerant cycle repaired only by JULABO service technicians or qualified specialists.
- If refrigerant leaks, stop the device immediately and ventilate the room thoroughly.

Wear personal protective equipment!

Lacking or unsuitable personal protective equipment increases the risk of health damage and injury.

Personal protective equipment includes, for example:

- Work gloves
- Safety shoes
- Protective clothing
- Breathing protection
- Hearing protection
- Face and eye protection
- Specify and provide personal protective equipment for the respective application.
- Use only personal protective equipment that is in good condition and provides effective protection.
- Adapt personal protective equipment to the person, e.g., by size.

Keep safety symbols legible!

Safety symbols on the unit warn of dangers in hazardous areas and are an important part of the unit's safety equipment. Missing safety symbols increase the risk of injury to persons.

- Clean dirty safety symbols.
- Replace damaged and unrecognizable safety symbols immediately.

Maintenance and repair work!

Improper maintenance and repair work jeopardizes operational safety. This can result in serious injury or death.

- Only carry out work described in this operating manual. Switch off the unit and disconnect it from the power supply before carrying out any work.
- All other maintenance and repair work may only be carried out by a JULABO service technician or a qualified specialist workshop.

4.3 Safety symbols

The following safety markings are attached to the device.

Safety symbols	Description	Location
	Warning of a danger zone. Note operating manual	Back of the device
	Warning about hot surface	Condenser
	Warning about cold surface	Probe hose connection
	Warning of flammable refrigerant	Nameplate
	Read operating manual before switching on	Back of the device

5 Product description

5.1 Function description

This section describes the function of the device.

The JULABO immersion cooler IC50E is used for cooling liquids, e.g. in Dewar flasks, beakers or other vessels in conjunction with heating circulators, for continuous counter-cooling or as a dry ice substitute.

5.2 Functionality of the temperature control

The temperature control of the IC50E works as follows:

- Actual value is 0.3 K below setpoint g Cooling stops, waiting time of 8 minutes begins.
- Actual value is 0.3 K above setpoint g Cooling starts when waiting time has elapsed.

5.3 Operating and functional elements

The following figure shows the operating and functional elements and their position on the unit.

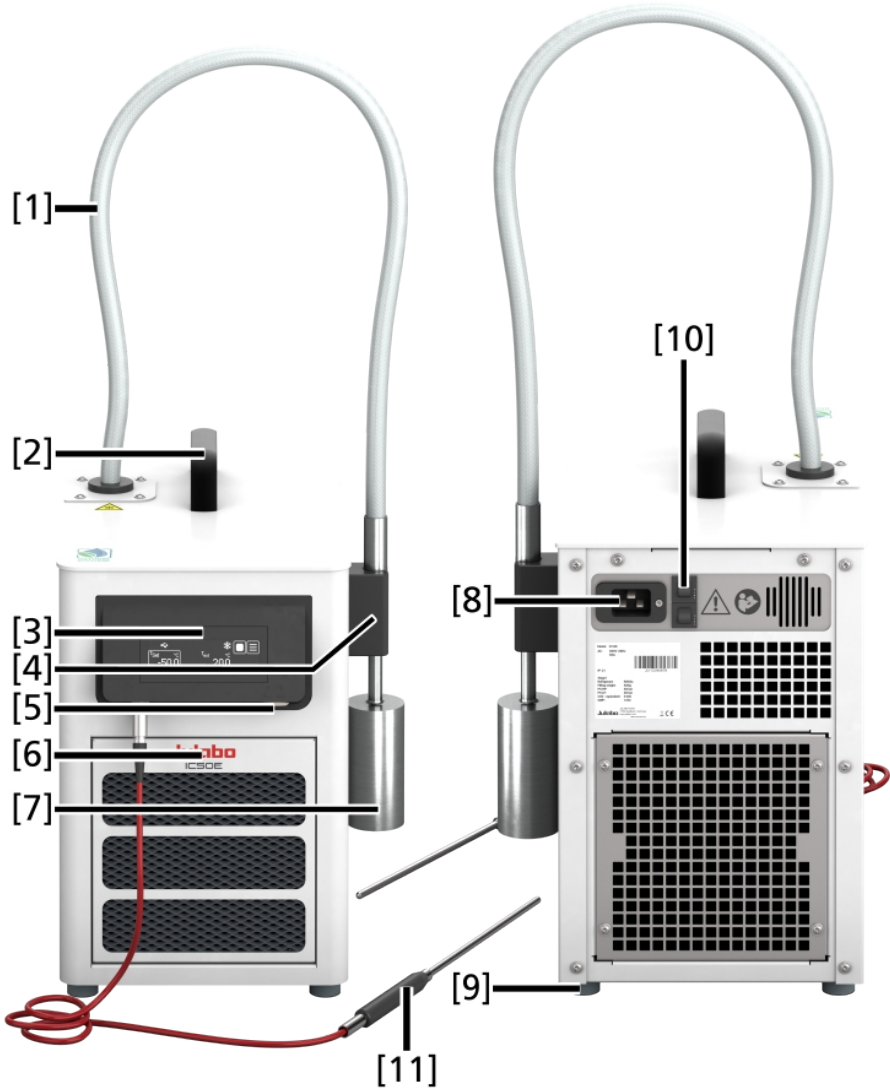

Operating and functional elements

1	Probe hose
2	Carrying handle
3	Display
4	Magnetic probe holder
5	Mains switch
6	Removable ventilation grid
7	Cooling probe
8	Mains connection
9	Rubber feet
10	Mains fuses
11	Pt100 sensor

The magnetic probe holder can be positioned anywhere on the side of the device housing. The minimum bending radius of the probe hose must be observed.



Magnetic probe holder



NOTE

Do not overbend the probe hose!

Overbending can damage the probe hose.

- The bending radius of the probe hose must not be less than 130 mm.
- At operating temperatures below -25°C , the bending radius must not be less than 200 mm.

5.4 Interfaces

5.4.1 USB-C interface

The unit has a USB-C interface.

The following functions can be used via the USB-C interface:

- Record data to external data storage device
- Save black box data to external data storage device
- Install firmware from external data storage device

Technical data for USB interface	
Output/input voltage	5 VDC
Maximum current strength/consumption	500 mA

5.4.2 Connection of Pt100 temperature sensor

The plug ext. Pt100 is used to connect an external Pt100 temperature sensor. The following section describes the wiring of the plug as well as the connection cable of the temperature sensor.

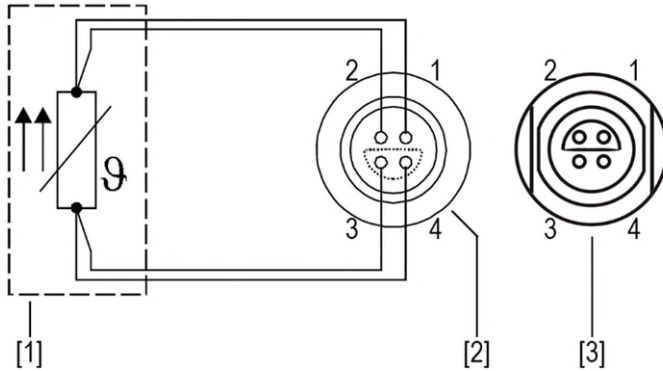

Connection of a external Pt100 temperature sensor

- [1] Temperature sensor Pt100
- [2] Plug, view of solder side
- [3] Connection socket on device

Pin	Signal
1	I+
2	U+
3	U-
4	I-

5.5 Operating interface





The device is operated by touchscreen. After the system is switched on and booted, the display shows the Home screen.







5.5.1 Softkeys and status icons

This section describes the softkeys and status icons found on the operating interface.



Touchscreen

Symbol	Description
	'External data storage device inserted' indicator
	'Record to external data storage device' enabled
	'Cooling activated' indicator
	'Current internal temperature' indicator

Softkey	Function
	Display error messages: Only the first error is shown. If there are multiple warnings, the cause of each must be rectified separately and the unit restarted.
	Display warning message: Only the first warning is shown. If there are multiple warnings, the cause of each must be rectified separately.
	Setpoint temperature settings
	Go to Main menu
	Start temperature control application
	Stop temperature control application

5.6 Main menu



Bring up the Main menu using the [≡] softkey on the home screen. The Main menu is divided into menu options, which respectively contain more submenus or in which settings can be specified.

The <Main menu> is divided into the following menu options:

- Adjust safety
- Evaluate data
- Install unit
- Settings
- Service
- About

5.6.1 Adjust safety menu



- Autostart yes/no
- Temperature limits:
 - Setpoint min./max.: Upper and lower setpoint temperature limit settings
 - High/Low temperature alarm, High/Low temperature warning: Alarm/warning limit settings



NOTE

Material damage caused by freezing water!

Freezing water can damage the device and the sample.

- When using water as the tempering fluid, do not temper below 5°C

5.6.2 'Evaluate data' menu



- Record data
 - Activate yes/no
 - Sampling time
- Save blackbox data
- Alarm memory

5.6.3 Install unit menu



- Reset unit

5.6.4 Settings menu



- Set language
- Set date and time
- Configure physical units
 - Temperature °C/°F
- Display brightness
- Screensaver yes/no



NOTE

The OLED display may be damaged if the screensaver is disabled!

Disabling the screensaver has a negative effect on the display's useful life.

The screensaver is enabled by default.

To prevent images from being burned into the screen, do not disable the screensaver.

5.6.5 Service menu



The <Service> menu is password protected. Only JULABO service technicians have access.

5.6.6 Menu About



- Display for device identity with voltage variant and firmware version

5.7 Alarm messages

Alarms and warnings are indicated on the display using error codes. Important error code descriptions can be found in the appendix. If you are unable to rectify a fault, contact Technical Service.

Warning:

In the event of a warning, the temperature control application is not interrupted. A warning message is displayed. A signal tone is emitted at intervals. The signal tone can be deactivated by touching the touchscreen. If the underlying cause of the warning is remedied, the signal tone ceases. Warnings may disappear automatically after a certain time, depending on the cause.

Alarm:

In the event of an alarm, the temperature control application is stopped. The actuators are switched off. At the same time, a continuous acoustic signal sounds and an alarm message is shown on the display. The signal tone can be deactivated by touching the touchscreen. The cause of the alarm must be remedied. A restart is required.

5.8 Technical data

Performance specifications measured in accordance with DIN12876. Cooling capacities up to 20°C measured with ethanol; over 20°C with thermal oil unless specified otherwise. Performance specifications apply at an ambient temperature of 20°C. Performance values may differ with other bath fluids.

Grouping of the device acc. to CISPR 11:

- The device is an ISM device of group 1, class A, which uses high frequency for internal purposes
- Class A: Use in an industrial electromagnetic environment

In accordance with IEC 61010-1, the device is designed for safe operation under the following ambient conditions:

- Indoor use
- Altitude up to 2000 m above sea level
- Ambient temperature +5 ... 40 °C (unless otherwise specified in the technical data)
- Maximum relative humidity 80 % for temperatures up to 31 °C, decreasing linearly down to 50 % relative humidity at 40 °C
- Pollution degree 2
- Overvoltage category II

The device is not suitable for use in an explosive environment.

* The immersion cooler is specially designed for cooling applications and therefore cannot be used for heating. The specification of the operating temperature range above the ambient temperature corresponds to the maximum permissible temperature in the application for which the immersion cooler is approved.

The lowest temperature of the operating temperature range corresponds to the minimum temperature that the probe reaches at its surface.

At ambient temperatures $>+35^{\circ}\text{C}$, the maximum temperature in the application is limited to $+40^{\circ}\text{C}$.

Technical data		Intracooler IC50E	
Cooling		Air	
Working temperature range	°C	-50 ... +100*	
Ambient temperature	°C	+5 ... +40*	
Noise level	dBA	55	
Protection class according to EN 60529		IP21	
Refrigerant		R1270	
Overall dimensions (W x D x H)	cm	23 x 46 x 40 (plus probe tube in the top)	
Body dimensions (W x D x H)	cm	23 x 44 x 36	
Cooling probe (L x Ø)	cm	10 x 5	
Connecting hose (L)	cm	110	
Weight	kg	23.5	
Mains connection	V/Hz	115/60	200-230/50/60
Nominal current consumption	A	7	4
Permissible voltage tolerance	%	±10	±5

5.8.1 Refrigerant

For safety reasons and in case of leakage in the refrigerant cycle, there is a specified room volume per kg of refrigerant permitted at the installation site so that no flammable refrigerant/air mixture can form. The amount of refrigerant is indicated on the nameplate.

For 0.008 kg of R1270 refrigerant, 1 m³ of space must be provided or a room volume of 125 m³ is required for 1 kg of R1270 refrigerant.

For 0.008 kg of R290 refrigerant, 1 m³ of space must be provided or a room volume of 125 m³ is required for 1 kg of R290 refrigerant.

Regardless of whether there is **one or more** refrigeration systems per room, the calculation/evaluation is **always the same** because it can be assumed that multiple leaks are not causally related or that a failure will occur as a consequence.

6 Transport and installation

	CAUTION
	<p>Risk of crushing by falling device! A device that is not secured appropriately can fall down during improper transport and cause crushing injuries.</p> <ul style="list-style-type: none">• Secure the device against tipping and falling during transport• Secure loose parts against falling during transport• Transport the device upright and with a suitable means of transport• Wear personal protective equipment

	NOTE
	<p>Do not overbend the probe hose! Overbending can damage the probe hose.</p> <ul style="list-style-type: none">• The bending radius of the probe hose must not be less than 130 mm.• At operating temperatures below -25°C, the bending radius must not be less than 200 mm.

	CAUTION
	<p>Escape of flammable refrigerants! Damage to the probe hose can cause refrigerant to escape.</p> <ul style="list-style-type: none">• Do not overbend the probe hose• If refrigerant escapes, switch off the appliance immediately, keep open flames and ignition sources away, ventilate the room well

	NOTE
	<p>Holding onto the control panel can damage it! Do not use the control panel as a handle during transport.</p>

6.1 Unpacking the device

This section describes how to unpack the device.

1. Check the packaging for transport damage.
2. Open the packaging so that the appliance can be removed from the packaging by the carrying handle or by lifting it by the base of the appliance.
3. Remove the appliance from the packaging and place it on a level, firm surface.

6.2 Transporting the device

This section describes how to transport the unit safely.

- ▶ The appliance is switched off and drained.
 - ▶ A suitable transport trolley is available.
2. Disconnect the mains plug from the appliance.
 2. Place loose parts, such as cables, on the transport trolley next to the appliance.
 3. Lift the appliance by the carrying handle or the base of the appliance and place it on a transport trolley.
 4. Secure the appliance against falling over and rolling away.
- ✓ The appliance is ready for transport and can be transported safely to its installation location.

6.3 Install the device at the operating location

This section describes how to transport the unit safely.

- Place the appliance on a level surface on a non-combustible base.
- The installation site must be frost-proof, dry and well ventilated.
- The free distance in front of the ventilation grids must be at least 20 cm.
- Do not move the appliance away from the installation site during operation.
- After installation, wait at least one hour before operating the appliance. Transport may have caused a shift in the oil, which must first settle.

7 Initial operation

7.1 Attach safety signs

The following section applies only to equipment working with natural refrigerants and operated in the US or Canada.

Once the unit is unpacked, first attach the enclosed safety signs.

- ▶ The device is unpacked.
- 1. Attach the enclosed safety labels to the indicated positions.
- ✓ The safety signs are attached.

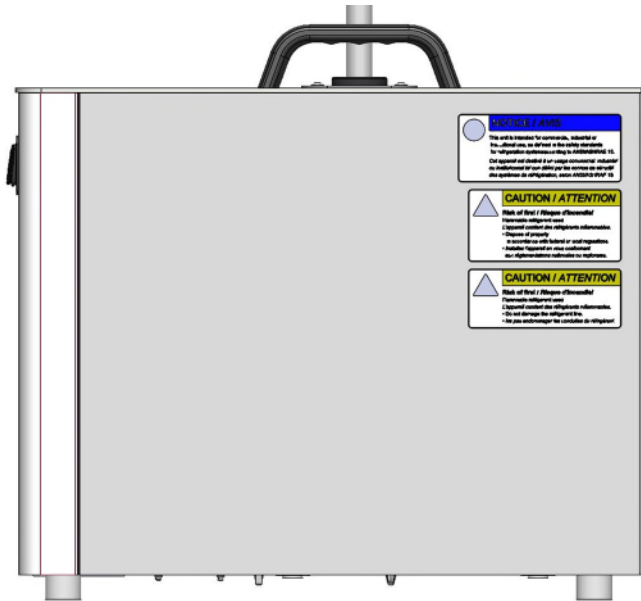

Right side of housing

7.2 Immerse the cooling probe in the medium

Before switching on the appliance, the cooling probe must be immersed in the medium.

The maximum immersion depth of the cooling probe is 180 mm.



WARNING

Cold combustion on iced-up cooling probe!

The cooling probe can ice up during operation. Risk of cold burns if the iced-up cooling probe is touched.

- Avoid direct contact with the cooling probe during operation
- Wear protective gloves



NOTE

Damage to the cooling probe / probe hose!

If the connection point between the cooling probe and the probe hose is immersed in the medium, medium can penetrate, freeze and cause damage.

- Do not immerse the probe hose and the connection point between the probe hose and cooling probe in the medium.
- Only the cooling probe may be immersed in the medium.

7.3 Connect the device to the power supply

This section describes how to connect the device electrically using the mains plug.

	<i>DANGER</i>
	<p>Danger to life due to electric shock!</p> <p>An electric shock can result in serious injury or death.</p> <ul style="list-style-type: none">• Only connect the unit to a mains connection protected by an earth-leakage circuit breaker ($I_a = 30 \text{ mA}$)• Only connect the unit to a mains power outlet with protective earthing contact• Do not attempt to use the unit if the mains cable is damaged• Do not attempt to use the unit if the housing is damaged

- ▶ The device is at its installation location.
- 1. Insert the device power cable plug into the mains connection socket on the rear of the device.
- 2. Insert the mains cable plug into the power supply socket.
- ✓ The device is connected to the electricity.

8 Operation

8.1 Switch on the unit

- ▶ The unit is connected and ready for operation.
- 1. Switch on the unit again at the main switch.
- ➔ The software boots and starts the unit. The display shows the unit name, voltage variant, and current configuration.
- ✓ The unit is switched on. Unit activates with the last operating mode enabled. If the auto start function is enabled, the unit starts directly with the most recent settings.

8.2 Switch off the unit

This section describes how to switch off the device.

- ▶ The device is switched on.
- 1. Stop a running temperature control application.
- ➔ The cooling symbol flashes, the refrigeration compressor is shut down.
- ⚠ Do not switch off the device until the cooling symbol stops flashing and the device is in standby mode.
- 2. Switch the device off at the mains switch.
- ✓ The device is switched off.

8.3 Configuring setpoint temperature

Device is running the temperature control application to the configured setpoint temperature. The setpoint temperature can be changed while the temperature control application is running. The set value is saved.

- ▶ The unit is switched on.



1. Press the [T_{set}] softkey.
- ↳ The setpoint temperature adjustment screen opens.

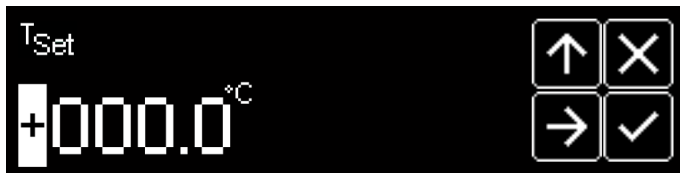

2. Adjust the setpoint temperature using the arrow keys or by swiping up/down on the display then confirm with [✓].
- ✓ The setpoint temperature is set and active. Adjustment of the setpoint temperature can be canceled by pressing the [x] button. The previous value is then retained.

8.4 Start temperature control application

A temperature application can be started directly on the unit.

- ▶ The unit is switched on.
 - ▶ The setpoint temperature has been configured.
1. Press the [▶] softkey.
 - ✓ The unit starts the temperature control application at once. The temperature control application can be stopped by pressing the [■] softkey.

8.5 Activate autostart function

The autostart function makes it possible to start a temperature control application directly using the mains switch or via an intermediate timer. The device is configured ex works in such a way that it switches to a safe operating status in the event of power failure. The autostart function is deactivated. The display shows "OFF."

- ▶ The device is switched on.
- 1. Call up the **<Main menu>**.
- 2. In the submenu **<Adjust safety>** select the menu item **<Autostart>/<Yes>**.
- ✓ The autostart function is activated. The next time the device is switched on, the temperature control application will immediately start with the preset values. A timer can be interposed and programmed. In this case the mains switch of the device must remain on.

	WARNING
	<p>Unattended autostart of the device</p> <p>When commissioning the appliance, ensure that an unattended auto-start of the appliance, e.g. after a power failure, cannot cause any danger to persons or systems.</p> <ul style="list-style-type: none"> • Ensure that the protective and warning devices on the appliance are functioning correctly.

8.6 Record data

The device can record data on an external storage medium. The **<Evaluate data>** menu is used to specify the conditions for this and start the recording. The recorded data can be used for subsequent evaluation.

- ▶ The unit is switched on.
- ▶ An external data storage device is available.
- 1. Connect the external data storage device to the USB-C port.
- 2. Go to the **<Main menu>**.
- 3. Go to the **<Evaluate data>** submenu.
- 4. Go to the **<Record data>** submenu.
- 5. Set the sampling time and confirm with [✓].
- 6. Select **<Enable>/<Yes>** in the submenu in order to activate the recorder.
- 7. Confirm your settings by pressing the [✓] softkey.
- ✓ Data recording will start. Data will be recorded at the specified interval until you stop the recording process.

9 Maintenance

9.1 Replace detachable power cord

The device is equipped with a detachable power cord.

The unit may only be operated with the included power cable. If the power cable needs to be replaced due to a defect, it can be reordered.

Order number	Designation
5.350.3300	Mains cable EU, 220-230 V
5.350.3310	Mains cable US, 115 V

9.2 Check safety symbols

The safety labels affixed to the device must be clearly legible at all times. Their condition must be checked every two years.

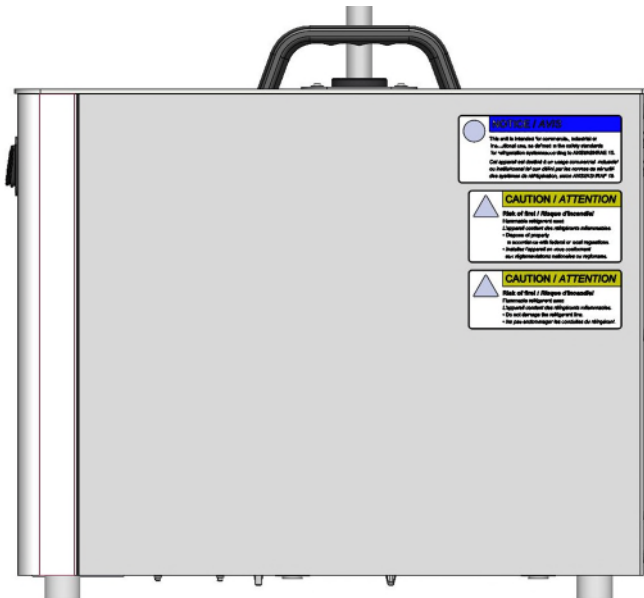

Right side of housing

Note (order no. 3.383.2640):

	NOTICE / AVIS
	<p>This unit is intended for commercial, industrial or institutional use, as defined in the safety standards for refrigeration systems according to ANSI/ASHRAE 15.</p> <p><i>Cet appareil est destiné à un usage commercial, industriel ou institutionnel tel que défini par les normes de sécurité des systèmes de réfrigération, selon ANSI/ASHRAE 15.</i></p>

Safety label (order no.: 3.383.2600):

	CAUTION / ATTENTION
	<p>Risk of fire! / <i>Risque d'incendie!</i> Flammable refrigerant used. <i>L'appareil contient des réfrigérants inflammables.</i></p> <ul style="list-style-type: none"> • Dispose of properly in accordance with federal or local regulations. • <i>Installez l'appareil en vous conformant aux réglementations nationales ou régionales.</i>

Safety label (order no. 3.383.2630):

	CAUTION / ATTENTION
	<p>Risk of fire! / <i>Risque d'incendie!</i> Flammable refrigerant used. <i>L'appareil contient des réfrigérants inflammables.</i></p> <ul style="list-style-type: none"> • Do not damage the refrigerant line. • <i>Ne pas endommager les conduites du réfrigérant.</i>

9.3 Clean device

The outside of the device should be periodically cleaned.

- ✘ Lint-free cloth
- ✘ Mild cleaning agent

	NOTE
	Observe during cleaning! No decontamination or cleaning agents are used which could cause a HAZARD as a result of a reaction with parts of the equipment or with material contained in it.

	NOTE
	Damage to the electronics due to water penetration! Ingress of water can damage electronic components of the device and thus lead to failure of the device. <ul style="list-style-type: none">• Clean the outside of the device with a damp cloth only• Prevent water from entering the device

9.4 Cleaning condenser

From time to time, the condenser on the front of the device should be cleaned to maintain full cooling capacity.

	CAUTION
	Risk of fire with flammable refrigerants! If the device contains a flammable refrigerant, there is a risk of fire if the refrigerant circuit leaks. <ul style="list-style-type: none">• Do not damage the refrigerant lines• Do not damage the condenser fins• If refrigerant escapes, switch off the device immediately, keep open flames and sources of ignition away, and ventilate the room well

- ▶ The unit is switched off.
- ▶ The unit is disconnected from the mains.
- ▶ The unit has cooled to room temperature.

1. Press the ventilation grid on the front of the appliance inwards to release the lock and remove it.



2. Use a vacuum cleaner to carefully remove dirt from the condenser.
☞ Make sure not to damage the condenser fins.



3. Reattach the ventilation grid. Press the ventilation grid inwards to lock it again.
✓ The condenser is cleaned.

9.5 Device storage

Take your device out of operation if you have not used it for a long time or, for example, it is to be sent to Technical Service for repair. Follow the procedure described to ensure that your device continues to function reliably even after being stored for a long period.

- ▶ The appliance is switched off and disconnected from the mains.
 1. Clean the appliance.
 2. Dry the device and all system components carefully, e.g. with compressed air.
 3. Store the appliance in a dust-free, dry and frost-free place.
- ✓ The device is stored safely and securely. It can be put back into operation when required.

9.6 Technical Service

If the unit shows faults you cannot resolve, please contact our Technical Service.

JULABO GmbH
Technical Service
Gerhard-Juchheim-Strasse 1
77960 Seelbach / Germany
Tel.: +49 7823 51-66
Service.de@julabo.com

Before sending a device to Technical Service, the following points must be observed:

- Clean and decontaminate the device properly to avoid endangering service personnel.
- Include a brief description of the fault.
- Package the device safely for shipment.

9.7 Warranty

The following Warranty Provisions shall apply to products sold in North America by Julabo ("Seller") to the entity shown as buyer ("Buyer") on Seller's invoice.

Initial Warranty

Upon Seller's receipt of payment in full for the products and subject to Buyer's compliance with the terms of sale and any other agreement with Seller relating to the products, Seller warrants to the Buyer that the products manufactured by the Seller are free from defects in material and workmanship for a period not to exceed two (2) years of operation from the date the product is shipped by Seller to Buyer (the "Initial Warranty").

EXCLUSION OF ALL OTHER EXPRESS WARRANTIES; EXCLUSION OF ALL IMPLIED WARRANTIES.

OTHER THAN THE INITIAL WARRANTY, NO OTHER EXPRESS WARRANTIES ARE MADE. ALL IMPLIED WARRANTIES OF EVERY TYPE AND KIND, INCLUDING BUT NOT LIMITED TO ANY IMPLIED WARRANTY OF MERCHANTABILITY OR FITNESS FOR A PARTICULAR PURPOSE OR USE, ARE EXCLUDED IN ALL RESPECTS AND FOR ALL PURPOSES. SELLER DISCLAIMS AND MAKES NO IMPLIED WARRANTIES WHATSOEVER.

Exclusions

The Initial Warranty does not include damage to the product resulting from accident, misuse, improper installation or operation, unauthorized or improper repair, replacement or alteration (including but not limited to repairs, replacements, or alterations made or performed by persons other than Seller's employees or authorized representatives), failure to provide (or use of improper) maintenance, unreasonable or unintended use or abuse of the product, or failure to follow written installation or operating instructions.

Buyer must return the product's record of purchase to the Seller or one of Seller's authorized representatives within thirty (30) days of the date the product is shipped by Seller to Buyer in order to make a claim under the Initial Warranty. Notwithstanding anything contained herein to the contrary, all glassware, including but not limited to reference thermometers, are expressly excluded from the Initial Warranty.

Buyer's sole remedies; Limitations on Seller's Liability

Buyer's sole and exclusive remedy under the Initial Warranty is strictly limited, in Seller's sole discretion, to either: (i) repairing defective parts; or (ii) replacing defective parts. In either case, the warranty period for the product receiving a repaired or replaced part pursuant to the terms of the Initial Warranty shall not be extended. All repairs or replacements performed by Seller pursuant to these Warranty Provisions shall be performed at one of the Seller's facility in Allentown, Pennsylvania, U.S.A. or at the facility of an authorized representative of Seller, which location shall be determined by Seller in its sole discretion; provided, however, that Seller may, in its sole discretion perform such repairs or replacements at Buyer's facility in which case Buyer shall pay Seller's travel, living and related expenses incurred by Seller in performing the repairs or replacements at Buyer's facility. As a condition precedent to Seller's obligation to repair or replace a product part under the Initial Warranty, Buyer shall (i) promptly notify Seller in writing of any such defect; (ii) shall have returned the product's record of purchase to Seller or to Seller's authorized representatives within thirty (30) days of the date the product is shipped by the seller; and (iii) assist Seller in all respects in its attempts to determine the legitimacy and basis of any claims made by or on behalf of Buyer including but not limited to providing Seller with access to the product to check operating conditions. If Buyer does not provide such written notice to Seller within the Initial Warranty period or fails to return the product's record of purchase as set forth above, Seller shall have no further liability or obligation to Buyer therefor. In no event shall Seller's liability under the Initial Warranty exceed the original purchase price of the product which is the subject of the alleged defect.

THE REMEDIES PROVIDED IN THE INITIAL WARRANTY ARE THE SOLE AND EXCLUSIVE REMEDIES AVAILABLE TO THE BUYER. NOTWITHSTANDING ANYTHING TO THE CONTRARY CONTAINED HEREIN, AND EVEN IF THE SOLE AND EXCLUSIVE REMEDIES FAIL OF THEIR ESSENTIAL PURPOSE FOR ANY REASON WHATSOEVER, IN NO EVENT SHALL SELLER BE LIABLE FOR BUYER'S MANUFACTURING COSTS, LOST PROFITS, GOODWILL, OR ANY OTHER SPECIAL, INDIRECT, PUNITIVE, INCIDENTAL OR CONSEQUENTIAL DAMAGES TO BUYER OR ANY THIRD PARTY AND ALL SUCH DAMAGES ARE HEREBY DISCLAIMED.

Assignment

Buyer shall not assign any of its rights or obligations hereunder without the prior written approval of Seller; provided, however, that if Buyer is a distributor of Seller, the rights and obligations of Buyer under these Warranty Provisions shall inure to the benefit of and be binding upon Buyer's customers who provide the product's proof of purchase to Seller pursuant to the terms set forth herein. Seller may assign any or all of its rights or obligations hereunder without Buyer's prior consent.

Governing Law

The Warranty Provisions and all questions relating to their validity, interpretation, performance, and enforcement shall be construed in accordance with, and shall be governed by, the substantive laws of the Commonwealth of Pennsylvania without regard to its principles of conflicts of law.

Waiver

Any failure of the part of Seller to insist on strict compliance with the Warranty Provisions shall no way constitute a waiver of such right. No claim or rights arising out of a breach of the Warranty Provisions by Buyer may be discharged in whole or in part by a waiver of the claim or right, unless the waiver is in writing signed by an authorized representative of Seller. Seller's waiver or acceptance of any breach by Buyer of any provisions of the Warranty Provisions shall not constitute a waiver of or an excuse for nonperformance as to any other provision of the Warranty Provisions nor as to any prior or subsequent breach of the same provision.

Freight

Seller will arrange and pay for shipping and handling for the return of the unit to the Buyer.

Out of Box Failure (OBF)

An Out of Box Failure (OBF) is defined as a product failure immediately following unpacking and installation of a newly delivered product. JULABO provides a 14-day grace period after the date of shipment, during which time the delivered product must be checked for defect. The same exclusions that apply to the regular warranty also apply to OBF classification. For example, JULABO will not be liable for transport damage, damage inflicted by the customer or any other party, or defects arising from improper installation or usage.

10 Disposal

10.1 Device disposal

When disposing of the device, the applicable country-specific guidelines must be observed.



This symbol on the product or its packaging indicates that it must not be disposed of with household waste. Proper disposal avoids negative effects on people and the environment and allows valuable raw materials to be reused. Information on collection points for old appliances can be obtained from the city or municipality or an authorised disposal company.

	CAUTION
	<p>Escape of flammable refrigerants!</p> <p>There is a risk of fire if flammable refrigerant escapes.</p> <ul style="list-style-type: none"> • Do not open the refrigerant circuit • Have the unit disposed of by a certified company in accordance with national or regional regulations

1. Contact an authorized waste disposal company for disposal of the unit.
 - ☞ Disposal of the unit in household waste, or similar facilities for the collection of domestic waste, is not permissible.
 - ✓ The unit can be properly disposed of.

11 Appendix

11.1 Alarms and Warnings

Alarm and warning messages are described in the table.

If a displayed error code is not described in the table or the error is still pending after switching off and on again, please contact Technical Service.

-03	The measured temperature is over the set high temperature limit.	<ul style="list-style-type: none"> • Increase "high temperature" temperature limit or decrease temperature setpoint.
-04	The measured temperature is below the set low temperature limit.	<ul style="list-style-type: none"> • Reduce "low temperature" temperature limit or increase temperature setpoint.
-15	The line of the external temperature sensor has short circuited or been interrupted.	<ul style="list-style-type: none"> • Check electrical connection to external temperature sensor.
-60	Internal read/write error.	<ul style="list-style-type: none"> • Switch off the unit at the mains switch, wait 4 seconds and then switch the unit on again.
-63	Watchdog function has responded.	<ul style="list-style-type: none"> • Switch off the unit at the mains switch, wait 4 seconds and then switch the unit on again.
-72	Unit is not configured.	<ul style="list-style-type: none"> • Load valid configuration file on unit.
-143	The set temperature limit for overtemperature alarm was exceeded.	<ul style="list-style-type: none"> • Increase overtemperature alarm temperature limit or decrease setpoint temperature.
-144	The set temperature limit for subtemperature alarm was exceeded.	<ul style="list-style-type: none"> • Decrease temperature limit of subtemperature alarm or increase temperature setpoint.
-183	Excessive power consumption via USB interface.	<ul style="list-style-type: none"> • Check inserted data storage device for errors and replace as necessary. The USB interface is not suitable for consumers that have a higher current draw than the maximum permissible current.

